

INSTRUCTION MANUAL



Type | STANDING-WAVE METER  
1234

GENERAL RADIO COMPANY

A

# INSTRUCTION MANUAL

## TABLE OF CONTENTS

# Type 1234 | STANDING-WAVE METER

Form 1234-0100-A

ID-B100

May, 1968

**NOTE:** This instrument is equipped with our new snap-on knob for added convenience and safety. Refer to the Service Section for details.

Copyright 1968 by General Radio Company  
West Concord, Massachusetts, U.S.A.

**GENERAL RADIO COMPANY**  
WEST CONCORD, MASSACHUSETTS, USA

## SPECIFICATIONS

**Meter Scales:** VSWR, 1 to 4, 3.2 to 10, 1 to 1.2, and 1 to 1.05; dB, 0 to 10, 0 to 1.6, and 0 to 0.45; bolometer current, 0 to 10 mA.

**Meter Accuracy:** 0 to 10-dB scale,  $\pm(0.01 \text{ dB} + 2\% \text{ of reading})$ ; 0 to 1.6-dB scale,  $\pm 0.02 \text{ dB}$ ; 0 to 0.45-dB scale,  $\pm 0.007 \text{ dB}$ .

**Attenuator:** Three separate attenuators: 20 dB in 10-dB steps, accuracy  $\pm 0.1 \text{ dB}$  per 10 dB; 45 dB in 5-dB steps, accuracy  $\pm 0.035 \text{ dB}$  per 5 dB, cumulative error 0.1 dB max; 5 dB in 1-dB steps, accuracy  $\pm 0.01 \text{ dB}$  per dB, cumulative error 0.03 dB max.

\* for source resistance  $< 1.5$  times optimum indicated below.

INPUT	Crystal				
	35 k $\Omega$	20 k $\Omega$	2 k $\Omega$	200 $\Omega$	Bolometer
Optimum Source R	35 k $\Omega$	20 k $\Omega$	2 k $\Omega$	200 $\Omega$	200 $\Omega$
Input Impedance	1 M $\Omega$	350 k $\Omega$ // 80 H	35 k $\Omega$ // 8 H	3.5 k $\Omega$ // 0.8 H	3.5 k $\Omega$ // 0.8 H
Sensitivity (fs)	1.2 $\mu\text{V}$	1 $\mu\text{V}$	0.32 $\mu\text{V}$	0.1 $\mu\text{V}$	0.1 $\mu\text{V}$
Noise*	0.12 $\mu\text{V}$	0.12 $\mu\text{V}$	0.036 $\mu\text{V}$	0.012 $\mu\text{V}$	0.012 $\mu\text{V}$

\* Equivalent input noise level with source resistance equal to optimum and with minimum bandwidth.

**Bandwidth:** 10 to 100 Hz, adjustable with constant gain.

**Frequency:** 1 kHz, adjustable  $\pm 30 \text{ Hz}$ .

**Gain Control:** Coarse and fine, 6-dB range.

**Bolometer Bias Current:** 4.3 and 8.7 mA, adjustable  $\pm 10\%$ .

Voltage limited for bolometer protection.

**Meter Speed:** Slow and fast, switch selected.

**Outputs:** Dc, 1.5 V max behind 1500  $\Omega$ . Ac, 0.1 V rms (1 to 4 VSWR range), 0.3 V rms (1 to 1.2 range), and 1 V rms (1 to 1.05 range); 500- $\Omega$  source impedance. Load resistance  $> 6000 \Omega$ .

### GENERAL

**Power Required:** 100 to 125 or 200 to 250 V, 50 to 60 Hz, 4 W. Or 22 to 35 V dc, 90 mA from ext battery; 1538-P3 suitable.

**Accessories Supplied:** Spare fuse, battery connector.

**Accessories Available:** 1538-P3 Battery and Charger.

**Mounting:** Flip-Tilt case.

**Dimensions** (width x height x depth):  $8\frac{3}{8} \times 8\frac{3}{4} \times 11\frac{1}{4}$  in. (215 x 225 x 290 mm).

**Weight:** Net, 9 lb (4.1 kg); shipping, 12 $\frac{1}{2}$  lb (6.0 kg).

# TABLE OF CONTENTS

Section 1	INTRODUCTION	
1.1	Purpose . . . . .	1
1.2	Flip-Tilt Case . . . . .	1
1.3	Controls and Connectors . . . . .	2
1.4	Accessories . . . . .	5
Section 2	INSTALLATION	
2.1	General . . . . .	7
2.2	Equipment Mounting . . . . .	7
2.3	Power Connection . . . . .	7
Section 3	OPERATION	
3.1	General . . . . .	9
3.2	Preliminary Checks . . . . .	9
3.3	Typical Operation . . . . .	9
3.4	Instrument Control Characteristics . . . . .	11
3.5	Battery Operation . . . . .	14
3.6	Measurement of SWR . . . . .	15
3.7	Attenuation Measurements . . . . .	17
Section 4	PRINCIPLES OF OPERATION	
4.1	Overall Description . . . . .	19
4.2	Circuit Details . . . . .	21
Section 5	SERVICE AND MAINTENANCE	
5.1	Warranty . . . . .	27
5.2	Service . . . . .	27
5.3	Equipment Required for Service . . . . .	27
5.4	Preparation for Test . . . . .	27
5.5	Trouble Analysis . . . . .	28
5.6	Test and Adjustments . . . . .	31
5.7	Repair and Replacement . . . . .	34
	Federal Manufacturers Code . . . . .	38
	Etched Board and Schematic Diagrams . . . . .	39
	Parts List . . . . .	42
	Appendix . . . . .	47

## 1.3 CONTROLS AND CONNECTORS

Table 1-1 lists and describes the 1234 controls and connectors.

TABLE 1-1  
CONTROLS, CONNECTORS AND INDICATORS

### SECTION 1

## INTRODUCTION

### 1.1 PURPOSE.

The Type 1234 Standing-Wave meter is a low-noise tuned 1-kHz amplifier calibrated for use with square-law detectors. Its primary purpose is to make standing-wave measurements using a slotted line having a square-law crystal or bolometric detector; other uses of this instrument include null detector for impedance/immitance measurements and insertion-loss measurements. Instrument attenuators and meter scales are calibrated for direct readout of standing-wave ratio or signal insertion loss measured with a square-law detector. The meter has a mirror scale and a knife-edge indicator to avoid parallax errors in readings.

Unique features of this instrument include an illuminated scale finder, direct scale switching, and a memory dial on the main attenuator that permits the instrument user to read insertion loss directly from visible indications, hence, the possibility of errors in scale reading are reduced when attenuator settings have to be remembered or computed. High-resolution expanded scales permit attenuation indications to be resolved into 0.02-dB increments, or standing-wave ratio indications to be resolved into 0.002-unit increments. The instrument can be connected directly to any 110- or 220- V power source, or can be op-

erated as a portable meter through a battery input jack. The battery plug is supplied with the instrument. Telephone-type tip jacks permit instrument indications to be recorded for permanent records, or for precision measurements. The meter is enclosed in a case that provides a stand for the instrument during use and a protective cover for the controls and meter face during storage or when carried.

### 1.2 FLIP-TILT CASE.

The Flip-Tilt case has three main parts: the instrument cabinet, a captive cover and a carrying-handle and lever assembly. When the instrument is closed for storage or transit the cover is locked in place over the front panel by means of slide latches on the carrying handle. To open the cabinet, slide the buttons out of the latches and push down on the carrying handle. The lever action of the handle raises the cabinet from the cover. The cabinet is then easily flopped into position for operation. The operating position may be fully open with the front panel exposed and the cover locked in place behind the instrument, or with the front panel tilted to almost any angle. A rubber gasket around the edge of the cover constitutes a dust- and moisture-resistant seal for the instrument.

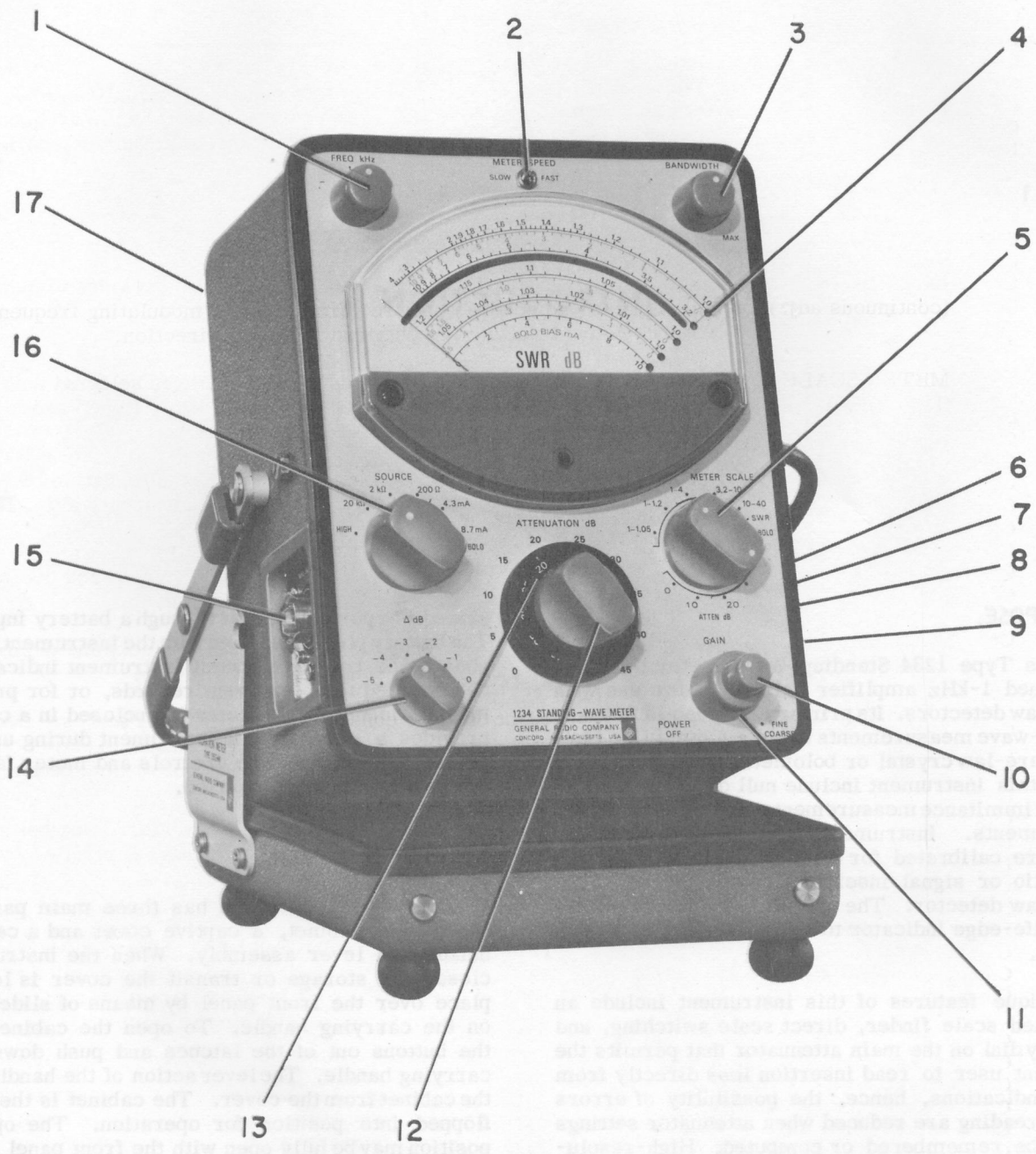

Figure 1-1. 1234 SWR Meter, controls and connectors

### 1.3 CONTROLS AND CONNECTORS.

Table 1-1 lists and describes the 1234 controls and connectors:

TABLE 1-1  
CONTROLS, CONNECTORS AND INDICATORS

Ref. No. Fig. 1-1	Control Name	Function
1	FREQ kHz (continuous adj.)	Tunes instrument amplifiers to test signal. Nominal range is between 970 Hz and 1030 Hz. The ccw position (-) is low frequency limit; the cw position (+) is high frequency limit; center position, (1.0) is nominal frequency of 1.0 kHz.
2	METER SPEED (switch)	Controls response of meter.
3	BANDWIDTH (continuous adj.)	Sets amplifier bandwidth. Minimum bandwidth provides higher signal-to-noise ratio, but requires a stable modulating frequency. Increasing bandwidth is obtained in the cw direction.
4	METER SCALE (lamps 1-5)	Indicate selected scale. Dot lights when scale is selected with METER SCALE switch (5). Scales 1-4 and 10-40 (SWR) are common.
5	METER SCALE (switch)	<p>Selects one of six meter scales or one of three attenuation levels. The attenuation levels are 0-, 10- and 20-dB, respectively. The meter scales are as follows:</p> <p>1-1.05 - Expanded scale calibrated in SWR (black) and decibels (red). Decibel scale range is 0 to 0.45.</p> <p>1-1.2 - Expanded scale calibrated in SWR (black) and decibels (red). Decibel scale range is 0 to 1.6.</p> <p>1-4 - First of three consecutive SWR (black) scales. Decibel (red) scale range is 0-10 dB. Attenuator section controlled by this switch provides 20 dB of attenuation.</p> <p>3.2-10 - Second of three consecutive SWR scales. Decibel scale range is 0- 10 dB. Attenuator section controlled by this switch provides 10 dB of attenuation.</p> <p>10-40 - Third of three consecutive SWR scales. All SWR indication are read on the 1-4 scale, but should be multiplied by a factor of 10. Attenuator section controlled by this switch is removed from the circuit.</p> <p>BOLO - Provides bolometer bias current when bolometric detector is used. When this switch position is used, the BOLO BIAS mA (linear) scale should be used. The linear scale can also be used to determine signal ratios.</p>

TABLE 1-1  
CONTROLS, CONNECTORS AND INDICATORS

<i>Ref. No. Fig. 1-1</i>	<i>Control Name</i>	<i>Function</i>
6 (not visible)	(Slide switch)	Used to provide correct power connections depending on whether source power is 115 or 220 volts ac, 50- 60 Hz.
7 (not visible)	OUTPUT - AC (receptacle)	Used to drive external a-c recorder such as the GR 1521 Graphic Level Recorder. Standard 2-conductor type-I telephone jack.
8 (not visible)	OUTPUT - DC	See item 7.
9 (not visible)	BATT (multipin receptacle)	Battery pack receptacle used to connect battery source power to instrument. Mating connector supplied with instrument.
10	GAIN-FINE (switch pot.)	Trims gain of amplifier for precise setting of SWR meter cursor and application of primary power, concentrically mounted with (11). When in the fully ccw position, this control turns the instrument off.
11	GAIN-COARSE (continuous)	Controls amplifier gain within 6dB; for coarse setting of SWR meter cursor. Part of GAIN function and is concentrically mounted with (10).
12	ATTENUATION dB (switch rotary)	Ten-position switch used to make insertion loss measurements. Attenuation range: 0- to 45-dB in 5-dB increments.
13	Memory dial (control)	Indicates change in position of main attenuator. When (12) is used, this control is turned ccw until 0 shows in window. When the ATTENUATOR dB switch is rotated in the ccw direction, the number in the window indicates the amount of attenuation that has been subtracted.
14	$\Delta$ dB (switch)	Attenuator used to obtain 1-db steps between 5-dB increments obtained with (10).
15	1 kHz INPUT (receptacle)	Accepts a 1-kHZ input signal. Has a GR874 coaxial connector.
16	SOURCE (switch)	Selects instrument optimum source impedance for maximum signal-to-noise ratio. Also used to set bolometer bias when bolometer detector is used.
	HIGH	- When in this position, optimum source resistance is approximately 35-k $\Omega$ .
	20k	- When in this position, optimum source resistance is 20 k $\Omega$ . (See section 3.)
	2k $\Omega$	- When in this position, optimum source resistance is 2k $\Omega$ . (See section 3.)
	200 $\Omega$	- When in this position, optimum source resistance is 200 $\Omega$ . (See section 3.)



**TABLE 1-1**  
**CONTROLS, CONNECTORS AND INDICATORS (Cont)**

<i>Ref. No. Fig. 1-1</i>	<i>Control Name</i>	<i>Function</i>
16 (cont)	SOURCE (switch)	BOLO - In this position 4.3 mA bias current is supplied to bolometer detector. Adjustable $\pm 10\%$ with BOLO CURRENT control (17). 4.3 mA
		BOLO - In this position 8.7 mA bias current is supplied to bolometer detector. Adjustable $\pm 10\%$ with BOLO CURRENT control (17). 8.7 mA
17	BOLO CURRENT (not visible)	Screwdriver adjustment used to adjust either low (4.3 mA, nominal) or high (8.7 mA, nominal) bolometer current within 10%.

#### 1.4 ACCESSORIES.

In addition to the accessories supplied with the 1234 SWR meter, General Radio has an extensive line of special test equipment for microwave measurements.

##### 1.4.1 ACCESSORIES SUPPLIED.

Accessories supplied with the 1234 SWR meter are a spare fuse and a battery connector.

##### 1.4.2 ACCESSORIES AVAILABLE.

Table 1-2 is a list of accessories available but not supplied. The accessories listed in this table are mentioned in text throughout this instruction manual. Refer to the General Radio catalog for a complete list. Table 1-3 is a list of Type GR874 Locking Adaptors to convert the input connector to other type of 50- $\Omega$  connectors.

**TABLE 1-2**  
**ACCESSORIES AVAILABLE**

<i>GR Type</i>	<i>Description</i>	<i>Purpose</i>
1538 - P3	Battery and Charger	For field operation of 1234 SWR meter
874 - R22LA	Patch Cord, coaxial	For connecting 1234 SWR meter and r-f signal source to slotted line
1521	Graphic Level Recorder	For making permanent record of SWR indications

**TABLE 1-3**  
**GR 874 LOCKING ADAPTORS TO OTHER SERIES**

<i>Mates</i>	<i>Type</i>	<i>Contains GR874 and . . .</i>	<i>Connects GR874 to . . .</i>	<i>Catalog Number</i>
Type BNC	874-QBJL	BNC Jack	BNC Plug	0874-9701
Type C	874-QCJL	C Jack	C Plug	0874-9703
Type MICRODOT	874-QMDJL	Microdot Jack	Microdot Plug	0874-9721
Type N	874-QNJL	N Jack	N Plug	0874-9711
Type SC	874-QSCJL	SC Jack	SC Plug (Sandia)	0874-9713
Type TNC	874-QTNJL	TNC Jack	TNC Plug	0874-9717
GR900	900-Q874	GR900	GR900 Precision 14-mm connector	0900-9883
Type OSM*/BRM	874-QMMJL	OSM/BRM Jack	OSM/BRM Plug	0874-9723
AMPHENOL APC-7	874-QAP7L	APC-7	APC-7 Precision 7-mm connector	0874-9791

\*Registered trademark of Omni Spectra, Inc.

## SECTION 2

# INSTALLATION

### 2.1 GENERAL.

The 1234 Standing-Wave Meter can be used as a portable instrument for bench or field use. The instrument is normally operated from a 115- or 230V, 50- to 60-Hz power source but it can also be operated from a 22- to 35-V battery power source (90-mA current drain) when no a-c power is available.

### 2.2 EQUIPMENT MOUNTING.

The overall dimensions of the 1234 SWR meter in the Flip-Tilt case are shown in Figure 2-1. Adequate space with respect to the dimension shown should be allowed for easy access to controls and connectors when the equipment is open and ready for use. The procedure for operating the Flip-Tilt case is shown in Figure 2-2.

### 2.3 POWER CONNECTION.

As previously noted the 1234 Standing-Wave meter can be operated from any of three power sources; 115- or 230-V, 50- to 60-Hz line, or battery. When operating from a 115- or 230-V line, the line select switch, located on the right side of the instrument, must be set to the position corresponding to the volt-

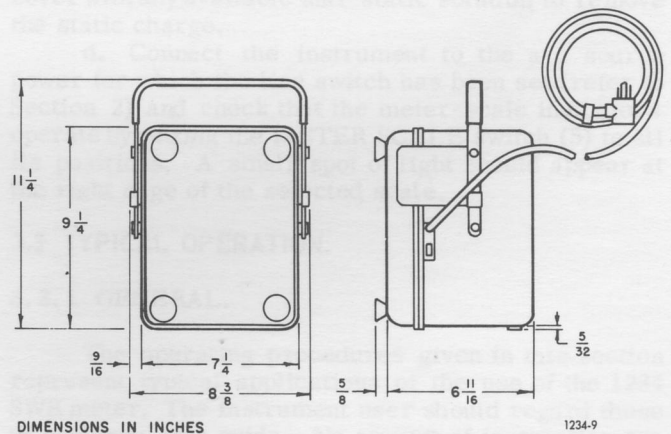

Figure 2-1. Over-all dimensions of 1234 Standing-Wave Meter in Flip-Tilt Cabinet Assembly.

age supplied by the source, prior to connection of the power cable. A 22- to 35-V battery capable of supplying 90 mA (1538-P3 Battery and Charger or equivalent) can be used as a source of d-c power for the instrument. The battery is connected to the BATT connector on the right side of the instrument.

**NOTE**

In this mode of operation, the normal power controls of the instrument, a-c line select and

POWER OFF switches, have no control over the application of power.

Application of power to the instrument is controlled by removing and connecting the battery.

**TO OPEN**

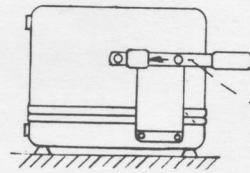

REST UNIT ON FEET AS SHOWN

PUSH LATCH BLOCKS IN DIRECTION SHOWN

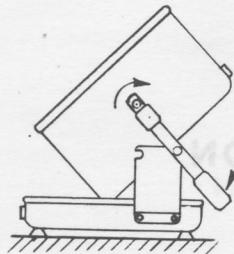

PRESS HANDLE DOWN AS FAR AS POSSIBLE

FLIP INSTRUMENT OVER AND HOLD AT DESIRED TILT

LET HANDLE UP

1617-37

Figure 2-2. Operation of the Flip-Tilt case.

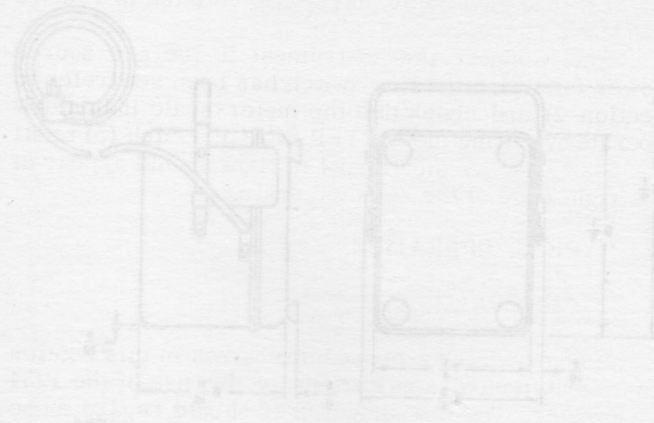

Figure 2-1. Overall dimensions of 1234 Standing-Wave Meter in Flip-Tilt Cabinet Assembly.

The previously noted the 1234 Standing-Wave meter can be operated from any of three power sources: 115- or 230-V, 50- to 60-Hz line, or battery. When operating from a 115- or 230-V line, the line select switch, located on the right side of the instrument, must be set to the position corresponding to the voltage supplied by the source. Prior to connection of the power cable, a 35- to 36-V battery capable of supplying 90 mA (1538-F3 Battery and Charger Assembly) can be used as a source of d-c power for the instrument. The battery is connected to the BATT connector on the right side of the instrument.

The 1234 Standing-Wave Meter can be used as a portable instrument for bench or field use. The instrument is normally operated from a 115- or 230V, 50- to 60-Hz power source but it can also be operated from a 35- to 36-V battery power source (90-mA current drain) when no a-c power is available.

**2.2 EQUIPMENT MOUNTING**

The overall dimensions of the 1234 SWR meter in the Flip-Tilt case are shown in Figure 2-1. Adequate space with respect to the dimensions shown should be allowed for easy access to controls and connectors when the equipment is open and ready for use. The procedure for operating the Flip-Tilt case is shown in Figure 2-2.

**2.3 POWER CONNECTION**

The previously noted the 1234 Standing-Wave meter can be operated from any of three power sources: 115- or 230-V, 50- to 60-Hz line, or battery. When operating from a 115- or 230-V line, the line select switch, located on the right side of the instrument, must be set to the position corresponding to the voltage supplied by the source. Prior to connection of the power cable, a 35- to 36-V battery capable of supplying 90 mA (1538-F3 Battery and Charger Assembly) can be used as a source of d-c power for the instrument. The battery is connected to the BATT connector on the right side of the instrument.

### SECTION 3

## OPERATION

### 3.1 GENERAL.

This section provides the instrument user with typical applications for use of the Type 1234 SWR meter together with general operating procedures relative to those applications. The instrument controls called out in this section are referenced to Figure 1-1 and to Table 1-1. The operating instructions contained in this section are of a general, rather than specific, nature. Before connecting the instrument into a test circuit, the user should first read Section 1.

### 3.2 PRELIMINARY CHECKS.

- a. Be sure that the a-c line switch is in its proper position before connecting the instrument to a power source (refer to Section 2). If a battery power source is used, this instruction does not apply.
- b. With the instrument disconnected from the power source, check that the meter pointer is in the 0 position (use the BOLO BIAS mA scale as the reference). Turn the screw located at the lower center of the meter face to obtain the zero indication.
- c. Before energizing the instrument, make certain that no static electricity charge is present on the meter cover. To do this, hold a 1/16 X 3-inch sliver of paper by one end and move the other end along the surface of the cover. If the loose end of the paper

sticks to the cover, static charge is present. Wet the cover with any available anti-static solution to remove the static charge.

d. Connect the instrument to the a-c source power for which the line switch has been set (refer to Section 2) and check that the meter-scale indicators operate by setting the METER SCALE switch (5) to all its positions. A small spot of light should appear at the right edge of the selected scale.

### 3.3 TYPICAL OPERATION.

#### 3.3.1 GENERAL.

The operating procedures given in this section represent typical applications of the use of the 1234 SWR meter. The instrument user should regard these procedures as a guide. No amount of instruction can substitute for good microwave-measurement practices. This instrument is intended for use with a precision coaxial slotted line and a stable source of r-f energy capable of being modulated at a square-wave frequency of 1.0 kHz. Unless noted, these instructions apply when the 1234 SWR meter is used to make standing-wave measurements. When the instrument is used for attenuation measurements, the meter dB (red) scale is used together with the ATTEN dB panel markings of the combined METER SCALE - ATTEN dB switch (5).

### 3.3.2 TYPICAL TEST SETUP.

A typical test setup for making microwave measurements using the 1234 SWR meter and a slotted line is shown in Figure 3-1. When standing-wave measurements are made, the test equipment is usually connected as shown. When attenuation measurements are made, this test setup can be modified so that the slotted line is not used. However, a detector is required in its place.

### 3.3.3 SIGNAL SOURCE.

The signal source should cover the desired frequency range and be capable of 100 percent modulation with a  $1.0 \text{ kHz} \pm 20\text{-Hz}$  square wave, the operating frequency of the 1234 SWR meter. Square-wave modulation should be used to minimize frequency modulation of the signal source. The Type 1264 Modulating Power Supply is recommended for use with General Radio oscillators that require external modulators. The General Radio Type 1360 Microwave Oscillator has an internal modulation source.

**Oscillator Frequency Shifts.** Often, when a slotted-line is shorted or open circuited, and a voltage minimum is sought to determine the position of an unknown, errors can be caused by shifts in the oscillator frequency with a change in the load impedance between the short-circuited and loaded-circuit conditions. This effect becomes more serious as the length of the signal line between the source and slotted line is increased. Oscillators that are tightly coupled to this line can have relatively large frequency shifts.

Such effects can be greatly reduced by the insertion of an attenuator or isolator between the signal source and the slotted line. If the insertion of the attenuator decreases the usable input from the signal source beyond tolerable limits, the oscillator tuning can be adjusted to compensate for the frequency shift. Under such circumstances, the amount of shift must be known for changes in loading conditions. However, outputs from signal sources are usually loosely coupled to their output circuits and the resultant frequency shifts are usually small. An attenuator such as the GR Type 874-G10L should be used between the signal source and the slotted line (refer to Figure 3-1).

**Harmonics.** Harmonics are another possible source of error in the measurement of high standing-wave ratios. Harmonic signals produced by signal sources are multiples of the generated frequency and thus produce standing waves along the line, which are summed with the standing-wave produced by the primary signal. Harmonics can also be generated by a nonlinear unknown. Because the minima for the harmonic signals are not located at the same points along the slotted line as those of the fundamental frequency, the likelihood of locating a harmonic is always present. GR 874 filters are useful for suppressing harmonics at frequencies up to 4.0 GHz.

**Frequency Modulation.** Frequency modulation of the applied r-f signal may produce errors when the standing-wave ratio is high. Frequency modulation is

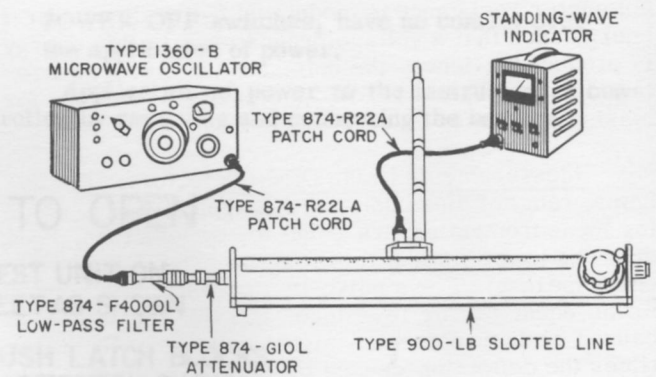

Figure 3-1. Type 1234 SWR Meter test setup for use with the GR 900-LB Precision Slotted Line.

usually produced when a high-frequency oscillator is amplitude modulated. The amount of frequency modulation for a given amount of amplitude modulation usually increases as the oscillator frequency approaches its upper limit. Square-wave modulation minimizes frequency modulation of the oscillator output.

### 3.3.4 SLOTTED LINE.

The slotted line is the basic instrument for making uhf and higher-frequency measurements. For any transmission system with source and load impedances mismatched, the mismatch prevents maximum power transfer because part of the power is reflected back toward the source. The power reflected from the load interferes with the incident (or forward) power causing voltage standing waves. These standing waves are the result of the summation of the incident and reflected voltages such that the maximum voltage will be the sum, and the minimum voltage, the difference between their respective maximum magnitudes. Voltage and current maxima or minima occur at half-wavelength intervals. Minimum and maximum impedance points, however, occur at quarter-wavelength intervals. The slotted line permits the instrument user to find these maxima and minima with precision, to measure VSWR, impedance, electrical length, and similar characteristics of unknowns.

### 3.3.5 DETECTORS.

There are two types of detector commonly in use with slotted lines: the crystal diode and the bolometer. Either type can be used with the 1234 SWR meter. In most cases, one or more diode detectors will be used with a slotted line.

There are two types of bolometers: the barretter and the thermistor. The barretter is more widely used and has a positive temperature coefficient. The thermistor bolometer is not widely used with slotted lines.

Barretter bolometers are usually fine tungsten wires mounted in a holder similar to that of a fuse with the exception that the bolometer may be substituted for the diode in the slotted-line diode holder. The

bolometer resistance is modulated by the detected r-f energy such that a voltage proportional to this energy is produced. Hence, the bolometer is also a square-law device. The 1234 SWR meter has provisions for biasing bolometer detectors.

Measurements Using Diode Detectors. The dynamic range of diode detectors is typically 30 to 35 dB for measurement errors equal to, or less than,  $\pm 0.1$  dB. The lower limit of this range is established by diode noise level. For a noise-produced indicated meter error equal to, or less than, 0.1 dB, the deflection caused by both noise and signal must be at least five times the deflection caused by the noise alone. This signal level will produce approximate full-scale deflection of the meter pointer when the front panel controls of the 1234 SWR meter are set as follows:

- a. SOURCE switch (16) set to 20k $\Omega$ .
- b. ATTENUATION dB switch (12) set to 0.
- c.  $\Delta$  dB switch (14) set to -5.
- d. METER SCALE switch (5) set to 10-40 SWR or to 0 dB.
- e. GAIN controls (10 and 11) fully cw.
- f. BANDWIDTH control (3) 3/4 ccw.

This represents an approximate 0.1-dB error only because of its dependence on the type of diode detector used. For an untuned diode detector, the r-f level required to obtain full-scale deflection of the meter pointer (for the instrument control settings listed above), is -60 dBm. The error produced at higher r-f input levels is a function of the deviation of the detector diode from its square-law region.

For a deflection error equal to or less than  $\pm 0.1$  dB, the corresponding high-level limit is reached when the r-f input level is raised 30 to 35 dB above the minimum r-f level required to obtain the low-level limit full-scale deflection of the meter pointer, as previously described above. The high-level signal will produce an approximate full-scale deflection when instrument controls are set as follows:

- a. SOURCE switch (16) set to 20k $\Omega$ .
- b. ATTENUATION dB switch (12) set to 5.
- c.  $\Delta$  dB switch (14) set to 0.
- d. METER SCALE or ATTEN dB switch (5) set to 1-4 (SWR scale) or to 20 (dB scale).
- e. GAIN controls (10 and 11) set to any position.

The upper limit can be raised by approximately 15 dB by adding a resistive shunt across the detector. The value of this resistor should equal the dynamic resistance of the diode. To find the value of the required resistor, connect a GR Type 874-TL Tee Connector between the existing detector output and the input to the 1234 SWR meter and proceed as follows:

- a. Connect a signal source, detector, as shown in Figure 3-1 and as described above.

b. Set the 1234 SWR meter front panel controls as follows:

- 1) METER SCALE switch (5) to 10-40 (SWR scale).
- 2) SOURCE switch (16) to 20k $\Omega$ .
- 3)  $\Delta$  dB switch (14) to 0.
- 4) ATTENUATION dB switch (12) to 5.
- 5) FREQ kHz control (1) to midrange (1.0).
- 6) METER SPEED switch (2) to SLOW.
- 7) BANDWIDTH control (3) 3/4 ccw.
- 8) GAIN controls (10 and 11) to midrange.

c. Adjust the output of the signal source to obtain full-scale deflection of the meter pointer. Adjust the FREQ kHz, BANDWIDTH, and GAIN controls as required to obtain a steady full-scale indication.

d. Add resistance between the unused arm of the Type 874-T tee connector and the coaxial return until the indication on the top scale (red) drops to 3.0 dB. Note the value of the added resistance and connect an equivalent resistor across the detector. A GR Type 1434 decade resistor, connected via a 274-NL Patch Cord terminated at one end with an 874-Q2 adaptor, would most conveniently permit this adjustment.

Measurement Using Bolometric Detectors. The dynamic range of bolometric detectors is typically 50 dB for measurement errors equal to, or less than,  $\pm 0.1$  dB. Both the low- and high-level limits of the input signal are respectively determined by the noise level and deviation of the bolometer in use from its square-law region. For an indicated deflection error of  $\pm 0.1$  dB, the input signal level is typically -50 dBm for a matched bolometer (200  $\Omega$ ). This signal level will produce an approximate full-scale deflection when the instrument controls are set as follows:

- a. SOURCE switch (16) to BOLO. (Bias set as required.)
- b. METER SCALE to 10-40 SWR/0 dB.
- c. BANDWIDTH control (3) 3/4 ccw.
- d. ATTENUATION dB switch (12) set to 0.
- e. GAIN controls (10 and 11) set to about mid-range.
- f.  $\Delta$  dB switch (14) set to -5.

The high-limit signal level will produce full-scale deflection with a  $\pm 0.1$ -dB error when the  $\Delta$  dB switch (14) is set to 0, the ATTENUATION dB switch (12) is set to 45 and the other control settings remain unchanged. It should be noted, however, that the limits and control settings given above are approximate for the specified error magnitude, because the error is dependent on the type of bolometer used for detection.

### 3.3.6 GROUND CURRENTS.

Before using the 1234 SWR meter for measurements, the test setup should be checked for ground currents. Connect the test setup for normal measurement conditions (Figure 3-1, for example) with the exception that the signal source r-f output connector should remain unconnected. Set the controls of the 1234 SWR meter for a sensitivity greater than that required to make the measurement and note the amount of deflection on the BOLO BIAS mA scale of the instrument.

Short the ground (outside) conductor of the patch cord, between the signal source and test setup, to the ground (outside) conductor of the signal-source output. If ground currents are present, the indicator of the 1234 SWR meter will show an increase in deflection.

In test setups where the only connection to the 1234 SWR meter is the detector, only the signal source should be connected to the a-c neutral (ground). The 1234 SWR meter has approximately 60- $\Omega$  inductive reactance between its case and its a-c line ground, at the nominal 1.0-kHz input frequency; in most cases, this reactance is sufficient to reduce ground currents to negligible amounts.

For those cases in which ground currents are still troublesome with the signal-source grounded, the usual cause of ground currents is an improper location of the signal-source ground point. If an apparent ground-current problem exists after the signal source has been grounded, disconnect the existing signal-source ground wire and reconnect one end of a separate ground wire to a terminal adjacent to the signal-source r-f output connector. Connect the other end of this separate ground wire to the a-c neutral (ground). Be sure that the ground wire provides a low-resistance path to ground.

When second connections, such as a recorder, are made to the 1234 SWR meter AC or DC output jacks, ground currents may prove more troublesome than for the single-connection case; this is especially true if the recorder has an unbalanced input.\* Ground-current effects can be eliminated if the recorder has a balanced (or differential) input. When the recorder has a balanced input, connect the AC or DC (whichever is used) output jack of the 1234 SWR meter to the balanced input of the recorder and leave the recorder ground input terminal unconnected; however, the recorder case must be returned to the a-c neutral (ground).

### 3.4 INSTRUMENT CONTROL CHARACTERISTICS.

Paragraphs 3.4.1 through 3.4.11 below provide general characteristics of the instrument controls. The instrument user should familiarize himself with

\*In this case disconnect the groundwire of either the signal source or the recorder.

these characteristics before using the 1234 SWR meter in a test setup. If the instructions given in these paragraphs are not followed, erroneous indications can result.

#### 3.4.1 SOURCE SWITCH.

The front-panel markings of the SOURCE switch (16) indicate the position that will give the best signal-to-noise ratio for particular values of source resistance. The optimum source resistance of the input pre-amplifier is approximately 35 k $\Omega$ ; for lower source resistances, the input transformer matches this value to 20k $\Omega$ , 2k $\Omega$ , and 200 $\Omega$ .

The approximate noise figure of the input pre-amplifier is a function of the source resistance as shown in Figure 3-2. The optimum noise figure is better at the high-resistance end because the losses of the input-transformer increase as the transformation ratio increases.

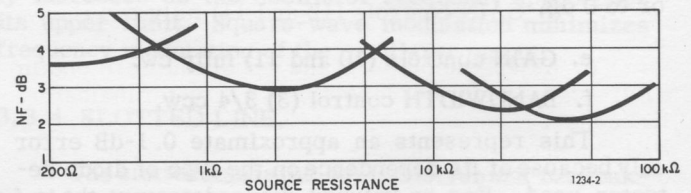

Figure 3-2. Variation of noise-figure for various resistances.

The SOURCE switch setting can also cause an error when the position of the ATTENUATION dB switch (12) is changed from the 15 to the 20-dB position; the input attenuator is first used in the 20-dB position of this switch. The attenuation error becomes perceptible if the actual source resistance is greater than double the value indicated by the SOURCE switch (16) position. Recommended positions for the SOURCE switch, for optimum signal-to-noise ratio, are given in Table 3-1 for various values of source resistance.

TABLE 3-1  
RECOMMENDED SOURCE SWITCH SETTINGS  
FOR VALUES OF SOURCE RESISTANCE

Source Resistance	SOURCE Switch Setting
Greater than 25k $\Omega$	HIGH
4k $\Omega$ to 25k $\Omega$	20k $\Omega$
400 $\Omega$ to 4k $\Omega$	2k $\Omega$
Less than 400 $\Omega$	200 $\Omega$

NOTE: A source resistance 4X greater than that indicated by the SOURCE switch position can cause an error of 0.1 dB in the attenuation provided by the ATTENUATION dB switch.

When the value of the source resistance is not known, and the optimum signal-to-noise ratio is not required, the SOURCE switch should be set to the HIGH position. To find the proper setting for the SOURCE switch when the value of the source resistance is not known, and the optimum signal-to-noise ratio is required, proceed as follows:

a. Connect the signal source, detector, and the 1234 SWR meter as shown in Figure 3-1.

b. Set the 1234 SWR meter front-panel controls as follows:

1) METER SCALE switch (5) to 10 - 40 SWR position.

2) SOURCE switch (16) to HIGH.

3) ATTENUATION dB switch (12) to 0.

4)  $\Delta$ dB switch (14) to -5.

5) FREQ kHz control (1) to midrange.

6) METER SPEED switch (2) to SLOW.

7) BANDWIDTH control (3) 3/4 ccw.

8) GAIN controls (10 and 11) fully cw.

c. Adjust the output of the signal source to obtain a full-scale deflection of the 1234 SWR meter indicator. If necessary, use the FINE and COARSE GAIN controls, FREQ control, and BANDWIDTH control as required to obtain a steady full-scale indication.

d. Without changing the value of the source resistance, remove the signal and note the new indication on the 1234 SWR meter. Read the BOLO BIAS mA scale and express this indication as a part of full scale; if, for example, the indication drops to 2, the signal-to-noise (S/N) ratio is 10/2, or 5, where 10 is the full-scale indication.

e. Change the SOURCE switch (16) setting to 20k  $\Omega$  and repeat steps c and d above.

f. Repeat steps c, d, and e, for the remaining two positions of the SOURCE switch and select the position that gives the highest signal-to-noise ratio. If two SOURCE-switch positions give nearly equal values of signal-to-noise ratio, choose the higher SOURCE switch setting.

### 3.4.2 FREQ kHz CONTROL.

The 1234 SWR meter is tuned to the incoming demodulated signal over a frequency range of 970 to 1030 Hz. This control permits the instrument user to accurately adjust the peak-response frequency of the instrument amplifiers, provided the BANDWIDTH control (3) is set at least 1/4 turn away from its maximum (3/4-turn cw) position. The BANDWIDTH control will not adversely affect the peak-response frequency if tuning is performed with the BANDWIDTH control set to its minimum (maximum ccw) position. The peak response frequency of the instrument varies linearly

between 970 and 1030 Hz with respect to rotation of the FREQ kHz control.

### 3.4.3 BANDWIDTH CONTROL.

The BANDWIDTH control (3) covers a half-power bandwidth range of 10 to 100 Hz. The change in gain over this range, is less than 1.0 dB. The minimum BANDWIDTH control setting (fully ccw) will give the maximum signal-to-noise ratio but requires a highly stable modulating frequency source. Figure 3-3 shows the variation in bandwidth with respect to rotation of the BANDWIDTH control.

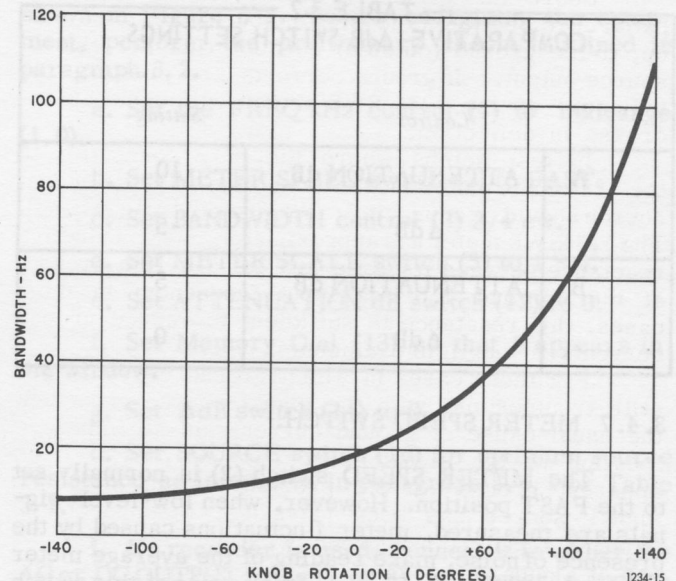

Figure 3-3. Variation of bandwidth with respect to knob rotation.

### 3.4.4 METER SCALE SWITCH.

The METER SCALE switch (5) is used when the 1234 SWR meter is used for SWR measurements and controls the relative sensitivity of the meter. When the instrument is used for attenuation measurements, the lower, or ATTEN dB panel, markings should be used rather than the METER SCALE panel markings. When the ATTEN dB markings are used, the topmost meter dB (red) scale should be read.

### 3.4.5 ATTENUATION dB SWITCH.

This switch is the main instrument attenuator and when used in conjunction with the METER SCALE or ATTEN dB switch (5), errors in the indication can be caused by a residual noise signal. At the highest sensitivity settings of the instrument (all attenuators set to 0), a residual noise signal sufficiently high to cause measurement errors is present. A meter deflection having a magnitude of at least 5X the residual noise magnitude (refer to paragraph 3.4.1) is required to reduce the error to 0.1 dB or less.



### 3.4.6 $\Delta$ dB SWITCH.

The  $\Delta$ dB switch (14) is calibrated from -5 to 0 dB to indicate that the 0-dB position is preferred when the  $\Delta$ dB switch is not in use. The reason for this is that the signal-to-noise ratio taken at the output of the instrument amplifier can be improved with this setting. The instrument settings given in Table 3-2 result in equal total attenuation but the settings listed in part B result in a higher signal-to-noise ratio at the instrument amplifier output.

TABLE 3-2  
COMPARATIVE  $\Delta$ dB SWITCH SETTINGS

	Control	Setting
A	ATTENUATION dB	10
	$\Delta$ dB	-5
B	ATTENUATION dB	5
	$\Delta$ dB	0

### 3.4.7 METER SPEED SWITCH.

The METER SPEED switch (2) is normally set to the FAST position. However, when low-level signals are measured, meter fluctuations caused by the presence of noise, make reading of the average meter deflections difficult. Changing the setting of this switch from the FAST to the SLOW position will reduce the noise-caused meter fluctuations.

### 3.4.8 BOLO CURRENT CONTROL.

The BOLO CURRENT control (17) can be adjusted over a range of  $\pm 10\%$  of the nominal value. This control is accessible through a hole in the rear cover of the instrument. Because this control is used to adjust both high- and low-bias currents, the adjustment of either will change the other. Bolometer current is monitored on the BOLO BIAS mA scale of the instrument when the METER SCALE switch (5) is set to BOLO.

Because the bolometer bias supply is a current source, there is no change in bias current when the resistance, presented at the input connector of the instrument, changes as a result of r-f modulation, as long as this resistance does not exceed  $240\Omega$ . The maximum open-circuit voltages are limited to 1.0 and 3.5 V, respectively, for the 4.3 mA and the 8.7 mA settings of the SOURCE switch (16). Voltage limiting prevents damage to the bolometer.

### 3.4.9 DC OUTPUT JACK.

Direct-current output voltage is developed across a 1.5-k $\Omega$  resistor in series with the meter move-

ment. The output circuit, including the instrument detectors, can be considered a current source. Hence, almost no change in meter current results from a change in the effective series resistance comprising the external load connected in parallel with the output.

The meter response speed, however, is approximately proportional to the meter series resistance. Hence, a low external load impedance (compared to the 1.5k $\Omega$  output resistor) will increase the response speed.

### 3.4.10 1.0 kHz OUTPUT JACK.

An a-c output is developed across feedback resistor R243. The load resistance connected across the 1.0-kHz output must be limited to an impedance of not less than 6 k $\Omega$ . The reason for this is that the ground-return path for the output circuit has been selected to minimize the effects of ground currents that could result from connection of an external instrument (such as a recorder) having an unbalanced input.

The ground-return path between the unbalanced input of a recorder and the output of the 1234 SWR meter at the AC output jack is not the most direct return for the 1.0-kHz output signal. A load impedance less than 6.0 k $\Omega$  could thus cause an error in one of the attenuators when the highest gain setting is used (ATTENUATION dB switch (12) set to 0,  $\Delta$ dB switch (14) set to -5, METER SCALE switch (5) set to 0, and GAIN controls (10 and 11) set fully cw).

### 3.4.11 MEMORY DIAL.

When the 1234 SWR meter is used for attenuation measurements, the Memory dial (13) on the ATTENUATION dB switch is especially useful. The ATTENUATION dB switch is first set to some convenient position, with the unknown disconnected, and the meter is set to 0 dB. The Memory Dial is then rotated counterclockwise until the stop is reached. When the stop is reached, a 0 digit appears in the Memory Dial window. This digit indicates the reference setting for the attenuation measurement.

After the unknown is connected, turn the ATTEN switch ccw to obtain an on-scale meter reading. The attenuation of the unknown is then indicated by the sum of the digit indicated in the Memory Dial window and the dB (red) scale indication of the meter.

## 3.5 BATTERY OPERATION.

The battery connector has been designed to mate with the output connector of the 1538-P3 Battery and Charger. Short circuiting the battery input terminals when the instrument is connected to, and powered by, the a-c power source, will not adversely affect instrument operation. Because the battery power source is connected ahead of the voltage regulator, battery voltage is not critical unless it drops below 22 volts. Any battery power source be-

tween 22 and 35 V, having a steady-drain current capability of 90 mA, will furnish sufficient power for operation of the instrument.

If both battery and a-c line power sources are connected to the instrument, the instrument circuits may draw power from the battery alone, from line power alone, or from both, depending on the condition of the battery and the magnitude of the line voltage. With a nominal line voltage of 115 V (or 230 V), and a battery voltage less than 29 V, for example, the instrument will draw all its power from the line and the battery will be isolated by an internal back-biased diode.

### 3.6 MEASUREMENT OF SWR.

#### 3.6.1 GENERAL

Measurement of SWR is accomplished by locating a voltage maximum by moving the slotted-line carriage and setting the signal source r-f output to obtain full-scale deflection (1.0) on the 1234 SWR meter. The slotted-line carriage is then moved to obtain a voltage minimum and the SWR is then read directly from the meter scale in use. Although this procedure is relatively simple, results depend to a great extent, on the care that is taken to obtain the voltage maximum and minimum and the correct settings of the front-panel controls of the 1234 SWR meter when the measurements are made.

#### NOTE

It is often necessary to measure successive maxima and minima and average the results.

Care in measurement practices will eliminate possible sources of error and prevent wide differences in results with different measurement techniques. The primary sources of SWR-measurement error result from improper slotted-line probe-depth setting, from probe reflections, and from the departure of the detector from its square-law characteristics at high signal levels. The instructions regarding the characteristics and dynamic ranges of diode detectors and bolometers in paragraph 3.3.5 should be read carefully before making SWR measurements.

The probe should be set in accordance with the specific instructions for the slotted line. Probe reflections can be minimized by use of a matched source; an isolator or attenuator is usually adequate. For SWR above 10, the probe loading at voltage maxima reduces the indicated SWR value.

The presence of the probe in the slotted line affects the SWR because it is a small admittance shunted across the line that increases as the amount of coupling is increased. This admittance has its greatest effect at the voltage maximum or point of highest impedance.

Procedures for adjusting probe depth and for obtaining coupling characteristics can usually be found in the instruction manual accompanying the slotted line

used in the test setup. Check that all requirements for obtaining the best possible 1234 SWR meter control settings have been satisfied as described in paragraphs 3.4.1 through 3.4.11.

#### 3.6.2. SWR BELOW 4

When the SWR of the unknown is expected to be less than 4, the SWR can be read directly from the 1234 meter scale.

Diode Detector Procedure. When a diode is used as the slotted-line detector, connect the r-f signal source, the slotted line, and the 1234 SWR meter as shown in Figure 3-1. Before energizing the equipment, perform the preliminary checks outlined in paragraph 3.2.

- a. Set the **FREQ kHz** control (1) to midrange (1.0).
- b. Set **METER SPEED** switch (2) to **FAST**.
- c. Set **BANDWIDTH** control (3)  $3/4$  cw.
- d. Set **METER SCALE** switch (5) to 1 - 4.
- e. Set **ATTENUATION dB** switch (12) to 0.
- f. Set **Memory Dial** (13) so that 0 appears in the window.
- g. Set  $\Delta$ **dB** switch (14) to 0.
- h. Set **SOURCE** switch (16) for optimum source resistance as instructed in paragraph 3.4.1 or Table 3-1.
  - i. If a recorder is used, connect it to either the **AC** or **DC OUTPUT** jacks (7 or 8), whichever is applicable according to paragraphs 3.3.6, 3.4.9, and 3.4.10 and follow recorder turn-on and alignment procedures.
  - j. Energize the signal source and set **COARSE** and **FINE GAIN** controls (10 and 11) to about midrange.
  - k. In combination, set the signal-source power level and slotted-line probe to obtain an upscale (toward 1.0) deflection on the selected meter scale. The top meter-scale indicator (4) should be lighted and an upscale indication obtained on the 1234 SWR meter.
    - l. Trim the 1234-SWR meter for up-scale reading by adjusting the **FREQ kHz** control for the best maximum. (In some cases it may be necessary to adjust the modulating frequency of the signal source.)
    - m. If the SWR indication fluctuates, adjust the **BANDWIDTH** control (3) counterclockwise until a steady indication is obtained.

#### NOTE

Such oscillation of the meter pointer may be caused by a noisy slotted-line detector diode; if such is the case, diode replacement will be necessary to obtain a more steady indication of the pointer, particularly at low signal levels.

- n. Continue trimming the 1234 SWR meter for up-scale reading by moving the slotted-line probe

carriage in the direction that obtains meter deflection towards full-scale. Also observe that slotted-line probe penetration is not excessive and that the slotted-line tuning stub is properly set.

o. Adjust both the COARSE and FINE GAIN controls or the signal-source power level, to obtain full-scale deflection (1.0) when the slotted-line carriage position for a peak has been obtained.

p. When the meter full-scale deflection has been obtained (meter peaked), move the slotted-line carriage probe to obtain a minimum meter reading. If the final down-scale indication is between 1.0 and 4, read the SWR directly from the indicated scale (top, black).

q. If the down-scale indication exceeds 4, change the METER SCALE switch to the 3.2 - 10 position and read the SWR from the indicated scale. If the SWR is greater than 10, switch the METER-SCALE switch to the 10-40 position, read the indicated SWR scale and multiply by 10. Check the residual noise level by disconnecting the signal source. If the noise level is more than 20% of the signal level, the reading is not accurate. Proceed to section 3.6.3.

r. If the downscale deflection is less than 1.2 and greater accuracy is required, change the METER SCALE switch to the 1 - 1.2 position and repeat steps 1 through o above.

s. When the meter full-scale deflection has been again obtained (maximum obtained on meter), move the slotted-line carriage probe in the direction that will give a new down-scale deflection of the meter pointer. If the final down-scale deflection is between 1.0 and 1.2, read the SWR directly from the indicated scale (black).

t. If the down-scale indication is less than 1.05, change the METER SCALE switch to the 1 - 1.05 position and repeat steps 1 through o above.

u. When the new meter full-scale deflection has been obtained, move the slotted-line carriage probe in the direction that will give a new down-scale deflection of the meter pointer. When the minimum has been reached, read the SWR directly from the indicated (black) scale.

#### NOTE

Averaging the SWR over several maxima and minima will yield more accurate results.

Bolometer Detector Procedures. When a bolometer is used as the slotted-line detector, connect the r-f signal source, the slotted line, and the 1234 SWR meter as shown in Figure 3-1.

#### CAUTION

Make sure that the bolometer is connected to the INPUT before applying power to the 1234, to protect the element.

a. Turn on the 1234 SWR meter by turning the FINE control cw from its POWER OFF position. If the battery power source is used, this instruction does not apply.

b. Set the METER SCALE switch to BOLO.

c. Depending on the bolometer bias current required, set the SOURCE switch to either 4.3 mA or 8.7 mA. The BOLO BIAS mA scale indicator should glow and the meter should show the corresponding current on the BOLO BIAS mA scale of the instrument.

d. If a bias current other than those indicated on the SOURCE switch is required ( $\pm 10\%$ ), set the SOURCE switch to the BOLO position closest the desired bolometer bias current and adjust the BOLO CURRENT screwdriver control (17) at the rear of the instrument, for the desired current. The current level should be indicated on the BOLO BIAS mA scale of the instrument.

e. To measure SWR, perform steps a through u of the diode-detector procedure, with the exception that step h should be ignored.

At the conclusion of the SWR measurements, be sure to return the current indication to its proper level. To do this, set the SOURCE switch to either the 4.3 mA or 8.7 mA position and adjust the BOLO CURRENT screwdriver control for the current indicated by the selected position. Check both positions for the proper indication.

#### 3.6.3. SWR ABOVE 10.

When the voltage minimum is obtained, and the 10 - 40 scale is in use, probe coupling can cause erroneous indications due to the magnitude of the change in signal level, when high values of SWR are involved.

At the voltage maximum, high probe coupling causes a loading effect with a resulting error in the SWR indication. However, at the voltage minimum, a high degree of probe coupling is required to detect the signal. These extremes in the probe coupling requirements at the maxima and minima can cause erroneous SWR indications. A measurement technique called width-of-minimum can be used to accurately extrapolate the voltage minimum. The width-of-minimum technique has its analogy in the measurement of bandwidth between the two half-power points. Figure 3-4 illustrates the width-of-minimum technique which is performed as follows:

a. Perform steps a and b in the diode detector procedure of paragraph 3.6.3.

b. When the 1234 SWR meter full-scale indication has been obtained, move the slotted-line probe in the direction that will give a minimum indication. This minimum may not be exactly definable if the indicating pointer of the meter fluctuates, the METER SPEED switch should be set to SLOW. When the minimum has been established, note the position of the slotted-line probe carriage.

c. Using the ATTENUATOR dB switch, the  $\Delta$ db switch, and the COARSE and FINE GAIN controls in combination, obtain an indication of 3 dB on the top (red) dB meter scale. This establishes a reference point for a signal amplitude double the minimum.

**NOTE**

Keep a minimum of 5 dB attenuation in the amplifier to avoid errors caused by residual noise.

d. Move the slotted-line carriage probe to obtain an indication of 0 on the red dB scale on each side of the previously established minimum and note the position of the slotted-line probe for each direction. Record the difference in slotted-line probe carriage position as the distance  $\Delta$  (refer to Figure 3-4).

e. Terminate the slotted line in a short circuit and move the slotted-line probe carriage to a new minimum indication and note the position of the probe carriage for this minimum.

f. Again move the slotted-line probe carriage to the next successive minimum and note the new position of the slotted-line probe carriage. Record the difference in slotted-line probe carriage position as the distance  $\lambda$ . The SWR can then be determined from the expression:

$$SWR \cong \lambda / \Pi \Delta$$

The above procedure eliminates the effects of poor probe coupling at low-signal levels because the new signal level is approximately twice the minimum.

**3.7 ATTENUATION MEASUREMENTS.**

The 1234 SWR meter is capable of measuring attenuations up to 80 dB of which 20 dB is controlled by the ATTEN dB functions of the common METER SCALE - ATTEN dB switch (5) and another 10 dB is obtainable on the topmost dB meter scale (if a detector with this dynamic range is available).

The main attenuator is the ATTENUATION dB switch (12), which covers a range of 45 dB in nine 5-dB steps. The Memory Dial (13), concentric with the main attenuator, permits direct readout of the attenuation controlled by the main attenuator (paragraph 3.4.11). The  $\Delta$ dB switch provides an interpolation of the main attenuator in 1-dB steps. This, in conjunction with the 0 - 1.6 dB expanded scale, provides a resolution of .02 dB.

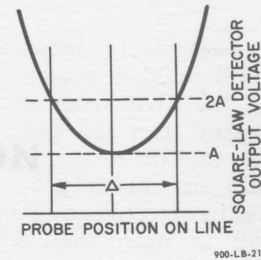

Figure 3-4. Method of measuring the width-of-voltage minimum.

A typical substitution technique step is shown in Figure 3-5 that utilizes the 1234 for attenuation measurements.

GR 874 coaxial attenuator plus on 874-VQL Detector (crystal type) and an 874-W50BL Termination are recommended for measurements up to 4GHz.

The Type 1003 and 1026 Standard Signal Generators, plus the Type 1360-B Microwave Oscillator, are suitable 1-kHz modulated signal sources that cover the same frequency range.

Adaptors to most common coaxial connector series from GR874 are available to facilitate introduction of unknown (Table 1-3). The instructions regarding the characteristics and dynamic ranges of diode detectors or bolometers in paragraph 3.3.5 should be read carefully before attempting to make attenuation measurements.

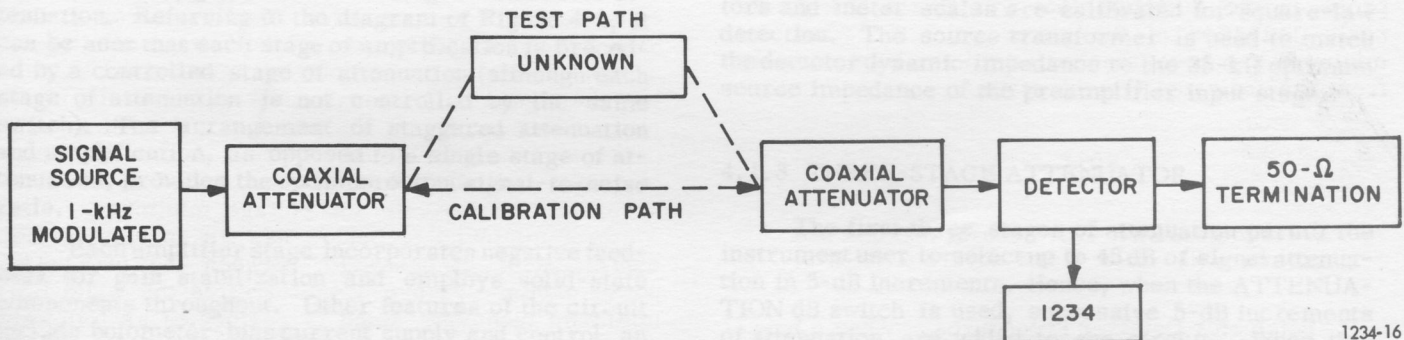

Figure 3-5. Attenuation measurement setup.

1234-16

## SECTION 4

# PRINCIPLES OF OPERATION

## 4.1 OVERALL DESCRIPTION.

### 4.1.1 GENERAL.

Figure 4-1 is the block diagram of the Type 1234 Standing-Wave Meter. This illustration relates instrument controls to the circuit functions they control. Figures 5-7 through 5-11 are the etched-circuit-board layouts and the complete schematic diagrams of the individual etched-circuit boards of the instrument.

The basic circuit comprises five stages of audio amplification together with six stages of discrete attenuation. Referring to the diagram of Figure 4-1, it can be seen that each stage of amplification is preceded by a controlled stage of attenuation (although each stage of attenuation is not controlled by the same switch). The arrangement of staggered attenuation and amplification, as opposed to a single stage of attenuation, provides the optimum output signal-to-noise ratio.

Each amplifier stage incorporates negative feedback for gain stabilization and employs solid-state components throughout. Other features of the circuit include bolometer-bias current supply and control, an electronic variable capacitor for tuning to the input modulation frequency, and a bandwidth control amplifier.

### 4.1.2 SOURCE SELECT CIRCUIT.

The source-select circuit includes the bolometer bias-control circuit, the six-position SOURCE switch, and the source-select transformer. When the SOURCE switch is in the 20-k $\Omega$ , 2-k $\Omega$ , or 200- $\Omega$  position, the 1-kHz input signal is transformer coupled through the first attenuator to the preamplifier input stage. During operation, the SOURCE switch is placed in the position that selects the optimum source resistance closest to the dynamic resistance of the detector used to sample the r-f source energy. Instrument attenuators and meter scales are calibrated for square-law detection. The source transformer is used to match the detector dynamic impedance to the 35-k $\Omega$  optimum source impedance of the preamplifier input stage.

### 4.1.3 THREE-STAGE ATTENUATOR.

The first three stages of attenuation permit the instrument user to select up to 45 dB of signal attenuation in 5-dB increments. Hence, when the ATTENUATION dB switch is used, successive 5-dB increments of attenuation are added to the circuit. When this switch is operated, the third attenuator is added to the circuit for all positions except 0; in this position, no attenuators are added to the circuit.

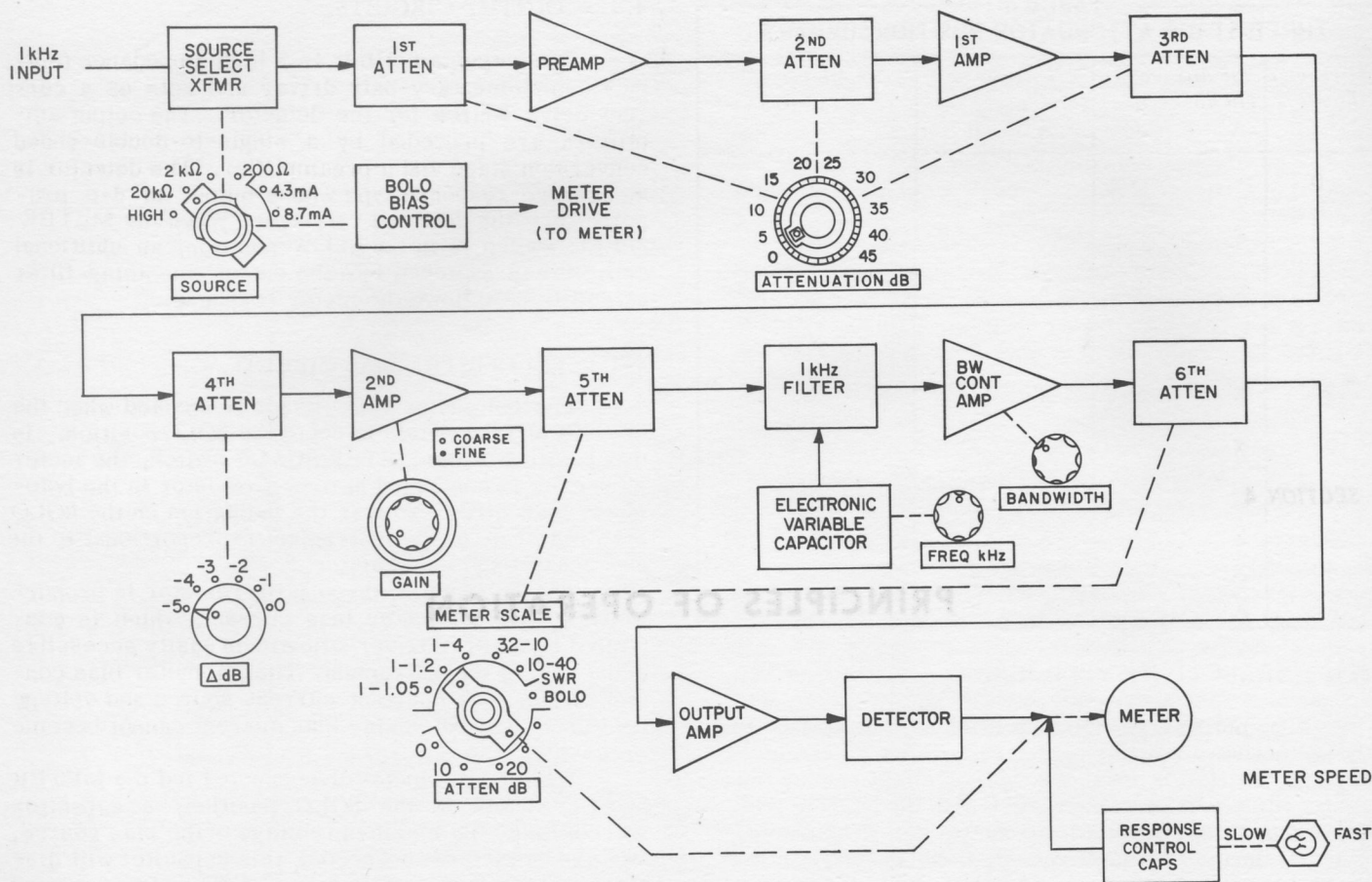

Figure 4-1. Type 1234, functional block diagram.

The second attenuator, located between the pre-amplifier and first amplifier stages, comprises two 5-dB sections of attenuation in cascade; depending on whether odd or even numbered increments of attenuation are selected by the instrument operator, either one (section A) or both (sections A and B) are added to the circuit. Hence, for an attenuation of 10, 20, 30, or 40 dB, only section A is added to the circuit, but for an attenuation of 15, 25, 35, and 45 dB, section B is also added to the circuit.

The first attenuator is added to the circuit when 20-dB attenuation is selected. In the 20-dB position, this attenuator introduces 10 dB of attenuation (5-dB each are also added by the second and third attenuators). Subsequently, an additional 10 dB of attenuation is added by the first attenuator at each subsequent position (30 and 40). The three-stage attenuation scheme is summarized in Table 4-1.

#### 4.1.4 INCREMENTAL ATTENUATOR.

The fourth stage of attenuation is controlled by the  $\Delta$ dB switch. This switch permits the instrument user to add or subtract up to 5 dB of attenuation from

the total attenuation indicated by the three-stage ATTENUATOR dB switch. When the  $\Delta$ dB switch is set to the 0 dB position, the fourth-stage attenuator inserts a 5-dB loss. When this attenuator is used together with the three-stage ATTENUATOR dB switch, the instrument user can easily obtain 1-dB increments directly from instrument switch settings.

#### 4.1.5 GAIN CIRCUIT.

Instrument gain is controlled by varying the amount of negative feedback in the first stage of the two-stage second amplifier. The outer COARSE control permits rough adjustments; the inner concentric FINE control permits final trim settings to be made, making these controls especially useful for setting reference indications on the meter scales. Output from the second amplifier is fed through the fifth attenuator, except when the METER SCALE switch is in the 10-40 position. When the METER SCALE switch is in this position, the output from the second amplifier is coupled directly to the selective amplifier. The FINE gain control also switches power to the instrument.

**TABLE 4-1**  
**THREE-STAGE ATTENUATOR POSITION SUMMARY**

Attenuator Position	1st Attenuator (10 dB/section)			2nd Attenuator (5 dB/section)		3rd Attenuator (5 dB/section)
	A	B	C	A	B	
0	-	-	-	-	-	-
5	-	-	-	-	-	X
10	-	-	-	X	-	X
15	-	-	-	X	X	X
20	X	-	-	X	-	X
25	X	-	-	X	X	X
30	X	X	-	X	-	X
35	X	X	-	X	X	X
40	X	X	X	X	-	X
45	X	X	X	X	X	X

#### 4.1.6 SELECTIVE AMPLIFIER.

The output from the fifth attenuator is applied to the selective amplifier. The associated electronic-variable capacitor uses the Miller effect to tune the 1-kHz filter to the incoming 1-kHz modulating frequency normally used to modulate the r-f source. Thus, if the modulating frequency is not exactly 1 kHz, the 1-kHz filter can be adjusted to this frequency.

The *FREQ-kHz* control determines the Miller-circuit gain and thus the effective capacitance used to trim the 1-kHz filter to the incoming signal.

The *BANDWIDTH* control adjusts the amplifier bandwidth around the center frequency determined by the peak response frequency of the 1-kHz filter and permits the bandwidth to be set from a minimum of 10 to a maximum of 100 Hz. A combination of positive and negative feedback is used in the selective amplifier to achieve variable bandwidth with constant gain. The output from the selective amplifier is applied through the sixth attenuator to the instrument output amplifier.

#### 4.1.7 METER SCALING CIRCUITS.

The *METER SCALE* switch controls the fifth and the sixth attenuators together with the meter. When the *METER SCALE* switch is set fully cw to the 10 - 40 position, the fifth attenuator is not in the circuit. However, in the 3.2 - 10 position, this switch inserts a 10-dB (indicated) signal loss through the fifth attenuator. In the 1 - 4 position, an additional 10-dB (indicated) loss is introduced through the fifth attenuator, before application to the selective amplifier. For both the 1 - 1.2 and 1 - 1.05 positions, the fifth attenuator has no further effect and the 20-dB (indicated) loss remains in the circuit. The output from the selective amplifier is coupled through the sixth attenuator to the output amplifier.

#### 4.1.8 OUTPUT CIRCUITS.

The output amplifier is a high-impedance (output) complementary-pair driver and acts as a current-drive source for the detector. The output amplifiers are preceded by a single-to-double-ended conversion stage and a preamplifier. The detector is an average-response type whose output is d-c proportional to the detected r-f power. When the *METER SPEED* switch is in the *SLOW* position, an additional capacitor is switched into the output smoothing-filter circuit to slow down the meter response.

#### 4.1.9 BOLOMETER BIAS CIRCUIT.

The bolometer bias circuit is enabled when the *METER SCALE* switch is set to the *BOLO* position. In this position of the *METER SCALE* switch, the meter movement is connected across a resistor in the bolometer bias circuit so that the indication on the *BOLO BIAS mA* scale of the instrument is proportional to the current through the resistor.

The current flow through the resistor is proportional to the bolometer bias current, which is controlled by a screwdriver adjustment easily accessible at the rear of the instrument. The bolometer bias control circuit is a constant-current source and voltage limiter so that bolometer bias current cannot become excessive.

With the bolometer disconnected and the *METER SCALE* switch in the *BOLO* position, a capacitor will charge to the maximum voltage of the bias source. When a bolometer is connected, this capacitor will discharge through the bolometer. If the voltage across the capacitor is high, its discharge current could damage the bolometer. Even though voltage-limiting protection is provided, the bolometer should always be connected before switching to the *BOLO* positions. When the *SOURCE* switch is in either the 4.3 mA or the 8.7 mA positions, the bolometer bias-control circuit automatically limits the current to the indicated level within 10%, depending on the position of the *BOLO BIAS* current adjustment control.

#### 4.1.10 POWER SUPPLY.

The power supply provides regulated -20 V dc to circuits of the 1234 Standing-Wave Meter. This power supply is capable of operating from a 115- or 230-V, 60-Hz, source or by auxiliary d-c power supplied from a 22- to 35-V battery. A wafer on the *METER SCALE* switch selects the meter-scale illuminating lamp, which is supplied by the 20-V power source through a series resistor.

### 4.2 CIRCUIT DETAILS.

#### 4.2.1 GENERAL.

This section discusses the detailed theory of operation and covers principles not already discussed in

the general description. The material in this section discusses the circuits on each of the instrument-etched-circuit boards together with their associated controls. Refer to Figure 5-7 through 5-11 for details.

#### 4.2.2 INPUT, ATTENUATOR AND PREAMPLIFIER.

The input, attenuator and preamplifier schematic diagram is Figure 5-9; unless otherwise indicated, all components described in this paragraph are shown on this schematic diagram.

Crystal-or-bolometric-detected 1-kHz signals are applied to connector J901, the instrument INPUT receptacle. For any position of switch S903 (SOURCE), except HIGH, transformer T902 is in the circuit. The incoming signal is fed through the low-pass filter consisting of inductor L901 and feedthrough capacitor C901. This low-pass filter prevents r-f signals leaking past the bypass capacitor of the detector from entering the preamplifier input to cause erroneous indications.

Transformer T902 has taps that are selected in various positions of SOURCE switch S903. This transformer adjusts the optimum source resistance at the input of the three-stage preamplifier to the values indicated by the SOURCE-switch panel markings. Hence, the transformer permits the choice of optimum source resistance.

The front wafer of ATTENUATION dB switch S904 is used to select taps on a logarithmic voltage divider comprising resistors R901 through R904. This voltage divider has a total resistance on the order of 1 M $\Omega$ . Because of the high total resistance, this voltage divider does not cause a significant reduction in the optimum signal-to-noise ratio.

The voltage divider performs the functions described for the first attenuator in paragraph 4.1.3. A quick calculation of the ratio of its tap resistance to its total resistance shows the voltage divider taps provide 1/1000, 1/100, and 1/10 of the input signal amplitude. These voltage ratios correspond to 60, 40, and 20 dB, respectively; hence, the taps occur at 20-dB intervals. This attenuation is double that indicated by the ATTENUATION dB switch position, because the instrument is calibrated for square-law detectors. This relationship is constant for all the attenuators in the instrument.

The preamplifier has three stages comprising transistors Q101, Q102, and Q103 together with their associated components. This circuit employs both a-c and d-c feedback. The a-c feedback through capacitor C105 and resistor R105 gives an amplifier input impedance of approximately 15 M $\Omega$ . The voltage gain of the preamplifier is approximately 33.

#### 4.2.3 SECOND ATTENUATOR AND FIRST AMPLIFIER.

The second attenuator is also part of the three-stage attenuator (S904); its components and those of the first amplifier are shown on Figure 5-9. The second attenuator comprises two 10-dB ladder (voltage) attenuators that are switched in or out of the circuit in the manner summarized in Table 4-1.

The output from either one or both stages of attenuation are coupled to the base of first amplifier Q201, which is part of the etched-circuit board for the amplifier, variable capacitor, selective section, and output amplifier. This amplifier also employs both a-c and d-c feedback.

Unbypassed resistor R203 furnishes negative a-c feedback and bypassed resistor R202 furnishes negative d-c feedback. The negative a-c feedback provides good gain stability and the negative d-c feedback good bias stability. Resistor R204, together with resistor R201, determines the required d-c bias, which establishes the operating point of the stage.

#### 4.2.4 THIRD AND FOURTH ATTENUATOR AND SECOND AMPLIFIER.

The third attenuator is a 10-dB section that is inserted in the circuit for all but the 0 position of three-stage ATTENUATOR dB switch S904. The fourth attenuator comprises a five-stage 2-dB ladder attenuator whose taps are selected by  $\Delta$  dB switch S905.

The second amplifier has two stages comprising transistors Q202 and Q203. The first stage, Q202, controls amplifier gain through two variable resistive controls (GAIN) that determine the magnitude of negative feedback in the first stage, transistor Q202. Variable resistors R912A and R912B are concentrically mounted; the inner shaft controls variable resistor R912B (FINE) and outer shaft controls R912A (COARSE). The output from this two-stage amplifier is fed to the fifth attenuator.

#### 4.2.5 TUNING, SELECTIVITY, AND OUTPUT AMPLIFIER.

The electronic variable capacitor (tuning), selective amplifier (bandwidth control), and output-amplifier components are shown on Figure 5-9; unless otherwise indicated, all components described in this paragraph are shown on this schematic diagram. The tuning, selective amplifier and output amplifier circuits are preceded by the fifth attenuator. This attenuator comprises two 20 dB (voltage) ladder sections whose output taps are selected by METER SCALE switch S906.

This switch selects up to 20 dB of (indicated) attenuation in 10-dB increments. The output from this attenuator is coupled to both the electronic variable capacitor, consisting of transistors Q204, Q205, and Q206, and to the bandwidth-control amplifier, consisting of transistors Q207, Q208, and Q209. The a-c signal fed to the bandwidth-control amplifier is coupled to the base of transistor Q207 through capacitor C215. The a-c signal fed to the electronic variable capacitor is coupled to the base of transistor Q206 through capacitor C213.

#### 4.2.6 ELECTRONIC VARIABLE CAPACITOR.

The electronic variable capacitor utilizes the Miller effect and the unique characteristics of an op-



erational amplifier to tune the 1-kHz filter in the bandwidth-control circuit to the frequency of the incoming demodulated signal.

In Figure 4-2, the electronic variable capacitor (EVC) effectively appears across variable inductor L201, as shown by the heavy signal path and  $R_o$  the equivalent output impedance. The EVC comprises transistors Q204, Q205, and Q206 together with their associated components. Variable resistor R918 is the instrument FREQ control. This control determines the gain of the stage.

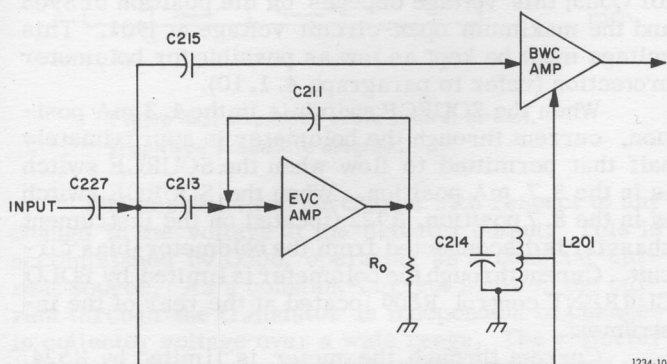

Figure 4-2. Electronic variable capacitor and bandwidth control amplifier, functional diagram.

Transistors Q205 and Q204 form a Darlington pair to provide a high input impedance and low output impedance, which is the characteristic sought in this circuit. The Miller effect causes the base-to-collector capacitance of an amplifier to appear larger than it actually is; in this circuit, the capacitance affected by the Miller phenomenon combines the base-to-collector capacitance of transistor Q206, the base-to-collector capacitance of transistor Q205, and the base-to-collector capacitance of transistor Q204; however, these capacitances are swamped by the large value of feedback capacitor C211, which provides the dominant characteristic of the circuit.

Effectively, the value of this capacitor is a function of the gain, "A" of the circuit, or,  $C_{\text{effective}} = C_{\text{actual}}(1+A)$ , and since the gain is controlled, the effective capacitance is made to vary by changing gain of the circuit with variable resistor R918.

Capacitor C210 and resistor R216 provide phase compensation between the input and output stages to compensate for the phase shift introduced by the stage output impedance,  $R_o$ , and the feedback capacitances.

#### 4.2.7 SELECTIVE AMPLIFIER.

The selective amplifier determines the selectivity of the final stage of amplification. The selectivity of this circuit is a function of the "Q" of the tuned circuit, or the 1-kHz filter; however, the Q of

this circuit is determined by bandwidth control variable resistor R919. The selective amplifier comprises transistors Q207, Q208, and Q209 together with their associated components. In this circuit, BANDWIDTH control R919 controls two feedback paths:

- 1) a negative feedback path directed through resistor R225 to the emitter of transistor Q207, and
- 2) a positive feedback path directed through resistors R253 and R252 to the tap on inductor L201 and the base of transistor Q207.

Feedback through both paths is required at the peak response frequency of the tuned filter; normally no change in gain will result at the peak response frequency when the feedback is changed with BANDWIDTH control R919. When this control is fully cw, feedback through both the positive and negative paths is zero and circuit bandwidth is maximum. When the BANDWIDTH control is fully ccw, circuit bandwidth is minimum. Emitter-follower Q209 provides a low-impedance output.

R253 is a trim adjustment for the amount of positive feedback required to maintain constant gain for bandwidths between 10 and 100 Hz at the peak response frequency.

Operation of the circuit is as follows: Suppose that the bandwidth of the circuit is narrowed as much as possible. Relative to circuit operation, the amount of signal coupled through capacitor C217 to the emitter and base of transistor Q207 is increased by the change in setting of the BANDWIDTH control, R919. However, the increase in positive feedback is offset by the negative feedback introduced at the emitter of transistor Q207.

R253 is set to a position where the amount of negative feedback permitted to appear at the emitter of transistor Q207 just offsets the amount of positive feedback; hence, there is no resulting change in circuit gain for any setting of BANDWIDTH control R919. The output of the selective amplifier is coupled through emitter-follower Q209 to the sixth attenuator and output amplifier.

**Fifth and Sixth Attenuators and Output Amplifier.** Both the fifth and sixth attenuators are used for scale switching. Although the fifth attenuator is electrically located ahead of the selective amplifier, it is described here because of its relationship to meter-scale switching. The fifth attenuator is a ladder type that provides up to 40 dB of voltage loss (20-dB indicated) in two 20-dB (actual) increments.

This attenuator is controlled by the METER SCALE switch to allow switching to the 3.2 - 10 and the 10 - 40 SWR (black) scales. Attenuation is 20-dB (40-dB actual) for the 1 - 4 SWR scale, 10 dB (20-dB actual) for the 3.2 - 10 scale, and 0 dB for the 10 - 40 scale. The sixth attenuator is a straight voltage divider whose taps are set for up to 20 dB of voltage loss in two 10-dB (actual) increments. Both attenuators are controlled by the METER SCALE switch.

Attenuation provided by the fifth attenuator is indicated on the lower scale of the METER SCALE switch on the front panel of the instrument (refer to Figures 1-1 and 4-1). The fifth attenuator comprises R914 through R917. The sixth attenuator comprises R246 through R250. R247 is used to adjust signal loss for 10 dB when the 1-1.2 meter scale is used.

**Output Amplifier.** The output amplifier circuit comprises Q210-Q214, together with their associated components. Transistors Q213 and Q214 form a high output-impedance complementary-symmetry amplifier. Transistor Q213 amplifies positive-going excursions of the input signal and Q214 amplifies negative-going excursions. Q211 and Q212 are used to convert the single-ended output from preamplifier Q210 to a double-ended input which appears at the respective bases of output stages Q213 and Q214. Q211 and Q212 also serve as low-impedance output drivers for the paired complementary output amplifier.

The a-c recorder signal appears at receptacle J903, a telephone-type jack. Diodes CR201 and CR202 in the collector circuits of Q211 and Q212, respectively, are for temperature compensation.

The output from the driver stages is coupled through C222 to the detector. During positive-going excursions of the output signal from the drivers, diode CR204 conducts, while simultaneously, diode CR203 is back biased. During this time, C224 charges. When the signal excursion goes negative, CR203 conducts. Currents through CR203 and CR204 flow through R243. The voltage across R243 is fed back to the emitters of Q211 and Q212 to ensure good linearity. Also, the a-c output signal is fed to connector J903 (1.0 kHz output), through R245.

During FAST or SLOW operation, depending on the position of S907, C505 or C505 and C225 are connected in the detector output circuit. When S907 is in the FAST position, C505 (on the power-supply etched-circuit board) is disconnected from the circuit and the time constant, established by C225 and R251 together with the meter movement resistance, is relatively short. However, when S907 is in the SLOW position, C505 and C225 are connected in parallel, making their capacitances additive. This increases the time constant by a factor of 5, so that the meter drive signal is relatively insensitive to fluctuations in the output signal. Current to drive the meter movement flows through R510, the meter movement, and R251.

#### 4.2.8 BIAS CIRCUIT AND POWER SUPPLY

The bolometer bias circuit, expanded-scale bias circuit, and power supply are located on the power-supply etched-circuit board (Figure 5-10). Unless otherwise indicated, all components described in this and subsequent paragraphs are located on this etched-circuit board. The schematic diagram is Figure 5-11.

**Bolometer Bias Circuit.** The bolometer-bias circuit is used to establish a constant current through a bolometer when used as the detector. Because the bolometer presents a resistance proportional to the

heating effect of the detected energy, with a constant current flowing through it, its output voltage is a function of that detected energy. The bolometer-bias supply furnishes the required constant current. The bolometer-bias circuit comprises Q504 and Q505, connected as a constant-current generator and driver, respectively, together with their associated components.

The bolometer-bias circuit is enabled when the SOURCE switch is set to one of the BOLO positions. M901 is connected into the circuit by placing S906 to the BOLO position. When this switch in the BOLO position, M901 is connected across the shunt, comprising R524 and R508. R515 and R511 establish base voltage for Q505; this voltage depends on the position of S903 and the maximum open-circuit voltage at J901. This voltage must be kept as low as possible for bolometer protection (refer to paragraph 4.1.10).

When the SOURCE switch is in the 4.3 mA position, current through the bolometer is approximately half that permitted to flow when the SOURCE switch is in the 8.7 mA position. When the SOURCE switch is in the 8.7 position, R922 (located on the instrument chassis) is disconnected from the bolometer-bias circuit. Current through the bolometer is limited by BOLO CURRENT control R509 located at the rear of the instrument.

Current through the meter is limited by R524, a calibration adjustment. The BOLO CURRENT control can be used to vary the bolometer current  $\pm 10\%$ . C108 on the preamplifier etched-circuit board (Figure 5-7) provides an a-c signal return for the lower terminal of the input transformer. C504 blocks any a-c signal present on the power-supply line from appearing at the input to the preamplifier.

**Expanded-Scale Bias Circuit.** The expanded-scale bias circuit is a stable constant-current source. Its purpose is to deliver an offset current to the output detector when the METER SCALE switch is in one of its expanded-scale positions (1 - 1.2 or 1 - 1.05 SWR). The current level produced by this circuit depends on the degree of expansion required. The meter displays the difference between the output (rectified 1.0 kHz) current and the offset current. Operation of the expanded-scale circuit is coupled with operation of the sixth attenuator through the METER SCALE switch (refer to paragraph 4.2.5). It is not, however, related to the other instrument attenuators; changes in the positions of the other instrument attenuators will not change the indicating scale previously selected with the METER SCALE switch.

Figure 4-3 is the simplified schematic diagram of the expanded-scale-control circuit. In this figure, the  $I_{sig}$  current-source represents the d-c current produced at the output of the detector;  $I_{offset}$  is the d-c current provided by the bias circuit.

It can be seen that the currents flow through the meter movement in opposite directions. Hence, the current seen by the meter will be the difference between  $I_{sig}$  and  $I_{offset}$ . R516 and R517 are used to adjust bias-control current levels for each of the expanded-scale switch positions.

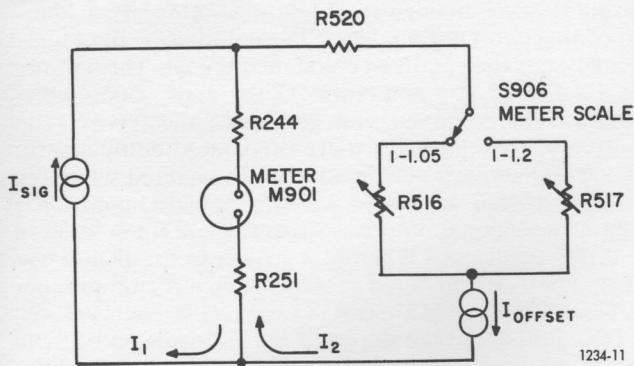

Figure 4-3. Expanded scale control circuit, simplified schematic diagram.

The current must not change with respect to any change in the voltage at the detector output. This is accomplished by Q506, operating as a constant-current source. As a constant-current source, the current through the transistor is independent of changes in collector voltage over a wide range. The collector current is determined by the emitter resistance and the transistor bias circuit.

Zener diode CR508 causes a constant voltage to appear at the base of Q506. This voltage, in turn, establishes a fixed voltage at the emitter of Q506, which fixes its collector current for any value of emitter resistance. CR507 makes the emitter-base voltage of the transistor relatively insensitive to changes in temperature.

The meter is returned to ground through R251. The voltage drop across this resistance is supplied to receptacle J902, a telephone-type jack that permits connection of a d-c recorder.

**Power Supply.** A regulated -20-V power supply provides power for operation of the 1234 Standing-Wave Meter (See Figure 5-11). The power supply operates

on either a-c or d-c input power. A-c power is provided from a 115- or 230-V, 60-Hz, source applied to the meter at connector PL901.

When the instrument is operated from a 115-V a-c source, S902 is set in the 100/125 position, which connects the primary windings of T901 in parallel.

When the instrument is operated from a 230-V a-c source, S902 is set in the 200/250 position, which connects the primary windings in series.

D-c power is provided from a 20-to 35-V battery that can be connected to the instrument at connector PL902.

A-c input power is stepped down by T901 and full-wave rectified by the bridge rectifier consisting of CR501 through CR504. The unregulated output of the rectifier is applied to the regulator.

D-c input power is applied directly to the regulator through steering diode CR509. This diode prevents possible instrument damage when battery polarity is inadvertently reversed or when the battery terminals are shorted.

The regulator consists of series regulator Q901, comparator Q503, and preregulator Q501. Regulation is achieved by monitoring the voltage across the output load and by controlling the conduction of the series regulator to maintain constant voltage across the output load. The voltage divider, consisting of R505 and R507 together with R506, monitors the voltage across the output load and provides a bias potential at the base of comparator Q503 that is proportional to the voltage across the output load. This voltage is compared with the fixed reference voltage established by Zener diode CR506 at the emitter of the control amplifier.

The bias arrangement of the control amplifier causes series regulator Q901 to increase conduction for decreases (becomes less negative) in voltage across the output load and to decrease conduction for increases in voltage (becomes more positive) across the output load. Preregulator Q501 provides input regulation for the series regulator by supplying a constant current to its base and, thereby, eliminating the ripple-current component of the unregulated output from the unregulated power supply.

## SECTION 5

# SERVICE AND MAINTENANCE

### 5.1 WARRANTY.

We warrant that each new instrument manufactured and sold by us is free from defects in material and workmanship, and that, properly used, it will perform in full accordance with applicable specifications for a period of two years after original shipment. Any instrument or component that is found within the two-year period not to meet these standards after examination by our factory, District Office, or authorized repair agency personnel will be repaired or, at our option, replaced without charge, except for tubes or batteries that have given normal service.

### 5.2 SERVICE.

The two-year warranty stated above attests the quality of materials and workmanship in our products. When difficulties do occur, our service engineers will assist in any way possible. If the difficulty cannot be eliminated by use of the following instructions, please write or phone our Service Department (see rear cover), giving full information of the trouble and of steps taken to remedy it. Be sure to mention the type and serial number of the instrument.

Before returning an instrument to General Radio for service, please write to our Service Department or nearest District Office, requesting a "Returned Material Tag." Use of this tag will ensure proper

handling and identification. For instructions not covered by the warranty, a purchase order should be forwarded to avoid unnecessary delay.

### 5.3 EQUIPMENT REQUIRED FOR SERVICE.

Table 5-1 lists the equipment required to service the 1234 Standing-Wave Meter. The specifications for each item listed are minimum requirements and not complete specifications. Other equipment with the same or better specification may be substituted, if the models listed are not available.

### 5.4 PREPARATION FOR TEST.

#### 5.4.1 INSPECTION.

Prior to performing the service and maintenance instruction of this section, the 1234 Standing-Wave Meter (SWR) should be inspected in accordance with the following:

a. Make certain that no static electricity charge is present on the SWR meter cover as directed in step c of paragraph 3.2.

b. Observe the zero position of the SWR meter pointer with the instrument turned off. If necessary, set the pointer to zero by adjusting the screw at the lower center of the instrument.

TABLE 5-1  
TEST EQUIPMENT

Name	Model	Specifications
Beat Frequency Audio Oscillator	Type 1304-B (General Radio)	Frequency range: 950 to 1050 Hz  Output: 5 V min
Electronic Voltmeter (vtvm)	Type 1806-A	Range: 20 V dc  Accuracy: 1%
Precision Decade Attenuator	Type 1450-TB (General Radio)	Range: 111 dB (in steps of 0.1 dB)
Impedance Matching Pad	GR 874-X	Impedance transformation: 600 to 200 Ω  (To be fabricated in accordance with Figure 5-1.)
Bolometer bias current supply load resistor	—	Value: 200 Ω Tolerance: ±5% Rating: 1/4 watt
Milliammeter	—	Range: 10 mA Accuracy: 2% Meter resistance: 20 Ω or less

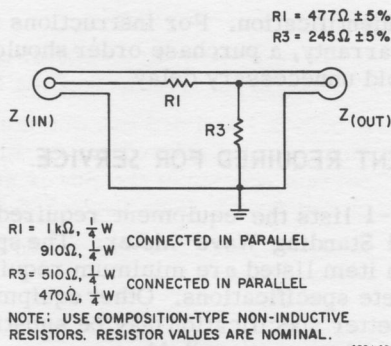

Figure 5-1. Impedance matching pad.

c. Visually inspect the SWR meter in accordance with Table 5-2.

#### 5.4.2 TEST SETUP.

Set up the SWR meter for test in accordance with the following steps:

- Set the power select switch to the position corresponding to the a-c voltage of the power source and connect power cable (refer to Section 2).
- Turn power on and allow 1/2-hour for instrument to warmup.
- Connect test equipment to the instrument as shown in Figure 5-2.

#### 5.5 TROUBLE ANALYSIS.

The trouble-analysis procedures are keyed to the test and adjustment procedures of paragraph 5.6. To trouble shoot the 1234 SWR meter, the test and adjustment procedures should first be performed to ascertain that the instrument is not out of adjustment. If an abnormal result is obtained in a given test, and adjustment fails to provide the necessary corrective action, reference should be made to the applicable paragraph reference of Table 5-3 for the probable cause of trouble and the corrective action to be taken. The corrective action in most cases is a reference to the voltage tests of Tables 5-4 through 5-6, which are supplied to assist in localization of the cause of trouble. Reference should also be made to Figures 5-7 through 5-11 for schematic diagrams and location of replaceable parts. To gain access to detail parts of the instrument refer to paragraph 5.7.

#### NOTE

The voltages listed in Tables 5-4 through 5-6 are nominal values; where no tolerance is given, a deviation of 10% is not considered abnormal. All voltages given are dc unless otherwise specified. The Fig. Ref column is provided to facilitate location of test points. Conditions of each test are given in the footnotes of each table.

**TABLE 5-2**  
**VISUAL INSPECTION**

<i>Item</i>	<i>Inspect for:</i>
Front panel	Improperly oriented or seated control knobs; cracked or broken meter window.
Switch contacts	Wear, pitting or breaks.
Wiring	Cold solder joints, breaks, frayed or charred insulation.
Etched-board assemblies	Charred or broken component parts and open etched wiring and pads.

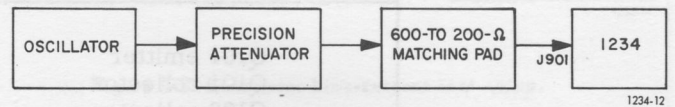

**Figure 5-2.** Test and calibration setup for 1234 SWR Meter.

**TABLE 5-3**  
**TROUBLE ANALYSIS**

<i>Test and Adjustment Procedure</i>	<i>Probable Cause</i>	<i>Remedy</i>
Power supply (paragraph 5.6.2)	Power-supply etched board  Transformer T901	Refer to Table 5-6 and check voltage between AT509 and AT510  If voltage is normal, proceed to check other voltages of power-supply etched board.  If voltage is abnormal, check a-c section of power supply.
Bolometer bias-current supply circuit	Power-supply etched board	If 8.7 mA output is as specified and 4.3 mA is incorrect, replace R922.  If both 8.7 and 4.3 mA outputs are incorrect, check bolometer-bias-current section of the power supply etched board. (See Table 5-6.)
Frequency response and bandwidth (paragraphs 5.6.4 and 5.6.5)	Preamplifier etched board	Refer to Table 5-4 and 5-5 to localize malfunction.
Meter linearity (paragraph 5.6.6)	Same as above	Same as above
Expanded scales adjustment (paragraph 5.6.7)	Power supply etched board	Refer to Table 5-6 and check expansion bias-circuit section of power-supply etched board.
Attenuator (paragraph 5.6.8)	ATTENUATION db and ΔdB attenuators	Refer to Figure 5-9 and check resistors of attenuators.
Sensitivity and noise level (paragraph 5.6.9)	Preamplifier or amplifier and associated attenuators	Refer to Tables 5-4 and 5-5 to localize malfunction on etched boards.  Refer to Figure 5-9 and check resistors of associated attenuators.
Output (paragraph 5.6.10)	Output amplifier	Refer to Table 5-5 and check output-amplifier section of etched board.

**TABLE 5-4**  
**PREAMPLIFIER TEST VOLTAGES**

<i>Test Points</i>	<i>Voltage dc to ground</i>
Q101 emitter	-11.6
Q101 collector	-9
Q102 collector	-7.5
Q103 collector	-4.7

\*SOURCE switch set to 200 and test equipment connected to 1234 Standing-Wave Meter as shown in Figure 5-2.

**TABLE 5-5**  
**AMPLIFIER, VARIABLE CAPACITOR,  
SELECTIVE SECTION, AND OUTPUT AMPLIFIER TEST**

<i>Test Points</i>	<i>Voltage dc to ground</i>
Amplifier Section 1	
AT222	-20
Q201 emitter	-13
Q201 collector	-9
Amplifier Section 2	
Q202 collector	-13
Q202 emitter	-9.3
Q203 collector	-5.7
Variable Capacitor Section	
Q206 emitter	-15
Q206 collector	-11
Selective Section	
Q207 emitter	-.55
Q207 collector	-16.8
Q208 collector	-5.2
Q209 emitter	-4.5
Output Amplifier	
Q210 emitter	-17
Q210 collector	-8.6
Q211 collector	-1.5
Q212 collector	-19
Q213 collector	-10.5

\*SOURCE switch set to 200 and test equipment connected to 1234 Standing-Wave Meter as shown in Figure 5-2.

**TABLE 5-6**  
**POWER SUPPLY TEST VOLTAGES**

Test Points	Voltage to Ground
<b>-20-Volt Section</b>	
AT509 - AT510	≈15 V AC
AT508	-29 Vdc
Q503 emitter	-12.5 Vdc
Q503 base	-13 Vdc
Q503 collector	-20.5 Vdc
AT507	-20 Vdc
<b>Bolometer Bias Current Supply*</b>	
Q505 base	-1.3 Vdc
Q505 emitter	-1.35 Vdc
Q504 emitter	-1.5 Vdc
<b>Expansion Bias Supply Section**</b>	
Q506 base	-10.4 Vdc
Q506 emitter	-11 Vdc

\*200Ω across J901. SOURCE switch set to 4.3 mA

\*\*1.05 SWR scale

## 5.6 TEST AND ADJUSTMENT.

### 5.6.1 GENERAL.

The procedures of the subsequent paragraphs are recommended for test and adjustment of the 1234 Standing-Wave Meter. Most of the procedures are divided into two parts: test and adjustment. The test procedure comprises a minimum performance standard test; the adjustment procedure, provided the circuit under test contains adjustable component parts, describes the method to adjust the circuit under test if the results are not within the tolerance specified. When adjustment fails to bring the circuit under test within the specified tolerance, reference should be made to Table 5-3 for corrective action. The procedures of this paragraph must be performed in the sequence given.

#### NOTE

Keep the 1234 SWR meter in its upright position when reading the meter. Holes are provided in the circuit boards to permit access to potentiometer shafts with a screw driver.

### 5.6.2 -20-V POWER SUPPLY.

Measure the voltage between terminals AT507(-) and AT505 to check the -20-V output of the power-supply etched-board assembly. Voltmeter should indicate -20 Vdc. Adjust R506 until voltmeter indicates nominal value of tolerance specified.

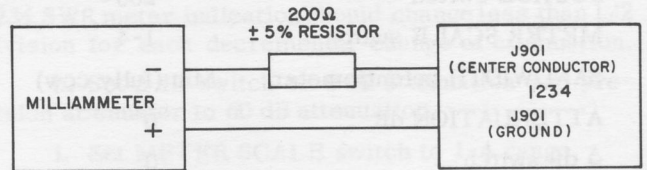

Figure 5-3. Bolometer bias-current test setup.

### 5.6.3 BOLOMETER BIAS-CURRENT SUPPLY.

To check the bolometer bias-current supply, proceed as follows:

- Connect milliammeter and a 200-Ω resistor in series with bolometer bias-current supply in accordance with setup and instructions of Figure 5-3.
- Set METER SCALE switch to BOLO and SOURCE switch to 8.7 mA. Both the milliammeter of the test setup and the SWR meter should indicate 8.7 mA.
- Set SOURCE switch to 4.3 mA and observe that both the milliammeter and the SWR meter indicate 4.3 mA.

#### NOTE

If the indication of step b is as specified and the indication of step c is not, re-adjust R509 for minimum error in the 8.7 mA and 4.3 mA settings.

- If the indications of step b or c are not as specified, adjust R509 for the specified indication on the milliammeter and adjust R524 for the specified indication on the 1234 SWR meter.

#### NOTE

Perform the test and adjustment procedures of paragraphs 5.6.4 through 5.6.10 with setup shown in Figure 5-2 unless otherwise specified.

### 5.6.4 FREQUENCY RESPONSE.

To check the frequency response of the 1234 SWR meter, proceed as follows:



a. Set front-panel controls as follows:

<u>Control</u>	<u>Position</u>
SOURCE switch	200
METER SCALE switch	1-4
BANDWIDTH potentiometer	Min (fully ccw)
ATTENUATION dB	0
$\Delta$ dB switch	0

b. Set oscillator to 1 kHz and adjust FREQUENCY potentiometer for peak response on SWR meter. If FREQUENCY potentiometer is not at 1.0 kHz, perform adjustment of step e, below, before proceeding to steps c and d.

c. Set FREQUENCY potentiometer to (-) and adjust frequency of oscillator for a peak response on 1234 SWR meter. Oscillator frequency should be equal to or less than 975 Hz.

d. Set FREQUENCY potentiometer to (+) and adjust frequency of oscillator for a peak response on 1234 SWR meter. Oscillator frequency should be equal to or greater than 1025 Hz.

e. If FREQUENCY potentiometer knob in step b, above, is not at 1 kHz set FREQUENCY potentiometer to 1 kHz and adjust coil L201 for a peak response on the 1234 SWR meter.

#### 5.6.5 BANDWIDTH

To check the gain of the 1234 SWR meter at maximum and minimum bandwidth, proceed as follows:

a. Set BANDWIDTH potentiometer to minimum (fully ccw) and set frequency of oscillator to 1 kHz. Adjust FREQUENCY potentiometer for a peak response on 1234 SWR meter.

b. Observe and record 1234 SWR meter indication.

c. Set BANDWIDTH potentiometer to MAX and observe that 1234 SWR meter indication is the same as recorded in step b.

#### NOTE

To adjust for equal gain at maximum and minimum bandwidth, perform steps d through f, below.

d. Set BANDWIDTH potentiometer to MAX and adjust oscillator frequency for peak response on 1234 SWR meter. Observe and record meter indication.

e. Set BANDWIDTH potentiometer to minimum (fully ccw). Readjust oscillator frequency for peak response and adjust R253 for indication recorded in step b, above.

f. Repeat the procedure of step a through c, above, to ascertain that the 1234 SWR meter indication, hence the gain, is the same for both minimum and maximum bandwidth.

#### NOTE

To check maximum and minimum bandwidth, perform steps g through l, below.

g. Set BANDWIDTH potentiometer to MAX.

h. Adjust oscillator frequency for maximum SWR meter deflection and set 1234 SWR meter to full scale.

i. Increase oscillator frequency until 1234 SWR meter indicates 1.5 dB below full scale and record oscillator frequency.

j. Decrease oscillator frequency until 1234 SWR meter indicates 1.5 dB below full scale and observe oscillator frequency. The difference in oscillator frequency of this step and step i must be equal to or greater than 100 Hz.

k. Set BANDWIDTH potentiometer to minimum (fully ccw).

l. Repeat steps h through j. The difference in frequency should be 10 Hz or less.

#### 5.6.6 METER LINEARITY.

To check meter linearity, proceed as follows:

a. Adjust frequency of oscillator to 1 kHz and set BANDWIDTH potentiometer to approximately mid-way of its range. Set ATTENUATION dB control to 5 dB,  $\Delta$  dB attenuator to 0, and METER SCALE switch to 1-4 range.

b. Adjust GAIN controls and oscillator output for full scale deflection of 1234 SWR meter.

c. Increase precision attenuation setting by 4 dB and observe that 1234 SWR meter indicates  $2 \pm 0.04$  dB.

d. Repeat step c for 10 and 20 dB and observe that 1234 SWR meter indicates  $5 \pm 0.1$  dB and  $10 \pm .02$  dB, respectively.

#### 5.6.7 EXPANDED SCALES.

To check the expanded scales of the 1234 SWR meter, proceed as follows:

a. Set front-panel controls to the positions specified in step a of paragraph 5.6.6.

b. Set METER SCALE switch to 1-1.2 range and adjust GAIN potentiometers and oscillator output level, if required, to obtain full-scale deflection of the 1234 SWR meter.

c. Increase the setting of precision attenuator by 2 dB. The 1234 SWR meter should indicate  $1 \pm .02$  dB.

d. If 1234 SWR meter indication is not within tolerance specified and below 1 dB, approximate the amount of the deviation and adjust R517 for an indication of three times the deviation above 1 dB. If, on the other hand, the 1234 SWR meter indication is above

1 dB, repeat the procedure adjusting R517 for three times the deviation below 1 dB. Check adjustment by repeating steps b and c, above.

e. Set METER SCALE switch to 1-1.05 range and adjust GAIN potentiometers and oscillator output level, if required, to obtain full-scale deflection of 1234 SWR meter.

f. Set precision attenuator to 0.6 dB. The 1234 SWR meter should indicate  $0.3 \pm 0.007$  dB.

g. If 1234 SWR meter indication is not within tolerance and below 0.3 dB, approximate the amount of the deviation and adjust R516 for ten times the deviation above 0.3 dB. If the 1234 SWR meter indication is above 0.3 dB, repeat the procedure adjusting R516 for ten times the deviation below 0.3 dB. Check adjustment by repeating steps e and f, above.

h. Check the gain of the 1234 SWR meter expanded scales by resetting precision attenuator to 0 dB and performing steps i through j, below.

i. Set METER SCALE switch to 1-1.05 range and adjust GAIN potentiometers and oscillator output level, if required, for full-scale deflection of 1234 SWR meter.

j. Set METER SCALE switch to 1-1.2 range and observe that meter is at full-scale deflection within  $\pm 0.2$  of a small division.

k. If 1234 SWR meter indication is not within tolerance, adjust the gain of the expanded scales by setting METER SCALE switch to 1-1.2 range and adjusting R247 for full-scale deflection of 1234 SWR meter. Check adjustment by repeating steps i and j, above.

#### 5.6.8 ATTENUATOR

To check attenuators of 1234 SWR meter, proceed as follows:

a. Set precision attenuator to 90 dB attenuation and oscillator output level to 5 V.

b. Set  $\Delta$ dB switch to 0 and set BANDWIDTH potentiometer, if not previously accomplished, approximately midway of its range.

c. Set METER SCALE switch to 1-1.05 range and ATTENUATION dB control to 0 dB.

d. Adjust GAIN potentiometers and oscillator output level for approximately mid-scale 1234 SWR meter indication.

e. Simultaneously adjust attenuation of ATTENUATION dB control in 5-dB increments and decrease attenuation of precision attenuator in 10-dB steps. The 1234 SWR meter indication should change less than 2 small divisions per incremental change in attenuation.

f. Set ATTENUATION dB control to 15 dB and precision attenuator to 60 dB.

g. Decrease attenuation of  $\Delta$ dB switch to -5 in 1-dB steps and increase attenuation of precision at-

tenuator by 2 dB for 1-dB change of  $\Delta$ dB switch. The 1234 SWR meter indication should change less than 1/2 division for each decremental change of attenuation.

h. Set  $\Delta$ dB switch to 0 dB attenuation and precision attenuator to 60 dB attenuation.

i. Set METER SCALE switch to 1-4 range.

j. Using GAIN controls and by adjusting oscillator output level, if required, set 1234 SWR meter at a division away from full-scale deflection.

k. Increase attenuation of precision attenuator by 20 dB and set METER SCALE switch to 3.2-10 range. The 1234 SWR meter indication should change 0.5 division or less.

l. Repeat the procedure of steps j and k switching METER SCALE switch from 3.2-10 range to 10-40 range. The 1234 SWR meter indication should change by 0.5 division or less.

#### 5.6.9 SENSITIVITY AND NOISE-LEVEL CHECK

To check the sensitivity and noise level of 1234 SWR meter, proceed as follows:

a. Set METER SCALE switch to 0 dB (10-40 SWR range).

b. With oscillator output range set to 50 mV, set oscillator output to 20 mV and precision attenuator to 80 dB. (Input voltage to the 1234 SWR meter is now  $0.2 \mu\text{V}$  behind  $200\Omega$ .)

c. Set ATTENUATION dB control to 0 dB and BANDWIDTH potentiometer to MAX.

d. Using GAIN potentiometers and  $\Delta$ dB switch, set 1234 SWR meter to full-scale deflection.

e. Disconnect oscillator from precision attenuator and observe that 1234 SWR meter indication is less than 20% of full scale, as read on the linear BOLO BIAS mA scale.

f. Reconnect oscillator to precision attenuator as shown in Figure 5-2.

g. Set BANDWIDTH potentiometer for minimum bandwidth (fully ccw).

h. Set oscillator output to 10 mV and repeat step d.

i. Disconnect oscillator from precision attenuator and observe that 1234 SWR meter indicates less than 10% of full scale.

#### 5.6.10 OUTPUT CHECK.

To check the outputs of the 1234 SWR meter, proceed as follows:

a. Set METER SCALE switch to 1-4 range and adjust GAIN potentiometers and oscillator output, if required, to obtain full-scale deflection of 1234 SWR meter.

b. Connect voltmeter to DC OUTPUT connector and measure voltage. Voltmeter should indicate 1.5 V dc.

c. Connect voltmeter to 1 kHz OUTPUT connector and measure rms voltages for the METER SCALE switch positions listed below at full-scale deflection of the SWR meter.

METER SCALE switch position	VOLTMETER INDICATION (volts rms)
1-4	0.1
1-1.2	0.3
1-1.05	1.0

## 5.7. REPAIR AND REPLACEMENT.

For repair and replacement, gain access to component parts of the 1234 SWR meter in accordance with the subsequent paragraphs. Dismantle equipment only to the extent required to effect repair and replacement.

### 5.7.1 REMOVAL OF INSTRUMENT.

The instrument is secured to the cabinet with two No. 10-32 Phillips-head screws, one screw in each side wall of the cabinet. Remove the two screws and slide instrument out of the cabinet.

### 5.7.2 DISMANTLING OF FLIP-TILT CABINET ASSEMBLY.

Should it be necessary to repair or replace a part of the flip-tilt cabinet assembly, proceed as follows:

a. Remove the two screws from the inside of the cabinet that secure each side of the handle assembly to the cabinet and separate the cabinet from the handle assembly.

b. Remove the two Phillips-head screws that secure the name plate and mounting plate of the handle assembly to the base and separate the base and handle assembly.

c. The flip-tilt cabinet assembly is now separated into its three major parts: cabinet, base and handle assembly. Repair these items as required. The parts that comprise the handle assembly are shown and listed in Figure 5-6.

### 5.7.3 ACCESS TO COMPONENT PARTS.

To gain access to component parts of the instrument, proceed as follows:

a. Remove the two Phillips-head screws that secure each of the output amplifier and power supply etched-board assemblies to the side wall of the instrument chassis and rotate each etched-board assembly outward as shown in Figures 5-4 and 5-5.

#### NOTE

Figure 5-4 shows the instrument with its shielding secured in place. Remove these shields, if required, to gain access to ATTENUATION dB switch S904 and SOURCE switch S903 and their associated parts which are shown in Figure 5-5.

b. Should it be necessary to replace parts of the preamplifier etched-board assembly (Figure 5-6), re-

move the two Phillips-head screws that secure the board to the side wall of the instrument. The board can now be moved out of the box without disconnecting the leads.

### 5.7.4 KNOB REMOVAL AND INSTALLATION.

**Removal.** If it should be necessary to remove the knob on a front-panel control, either to replace one that has been damaged or to replace the associated control, proceed as follows:

a. Grasp the knob with the fingers, close to panel or indicator dials, if applicable, and pull the knob straight out and away from panel.

#### CAUTION

Do not pull on the dial to remove a dial/knob assembly. Always remove the knob first.

b. Observe the position of the set screw in the now-visible bushing, with respect to any panel markings (or at the full ccw position of a continuous control).

c. Using a suitable hex-wrench release the set screw and pull the bushing off the shaft.

d. Remove and retain the black nylon thrust washer, behind the dial/knob assembly, as appropriate.

#### NOTE

To separate the bushing from the knob, if for any reason they should be combined off the instrument, drive a machine tap a turn or two into the bushing for a sufficient grip for easy separation.

**Installation.** To install a snap-on knob assembly onto a control shaft, proceed as follows:

a. Place the black nylon thrust washer over the control shaft, if appropriate.

b. Mount the bushing on the shaft, using a small slotted piece of wrapping paper as a shim for adequate panel clearance.

c. Orient the set screw on the bushing with respect to the panel-marking index and lock the setscrew with a hex wrench.

#### NOTE

Make sure that the end of the shaft does not protrude through the bushing or the knob will not set properly.

d. Place the knob on the bushing with the retention spring opposite the set screw.

e. Push the knob in until it bottoms and pull it slightly to check that the retention spring is seated in the groove in the bushing.

#### NOTE

If the retention spring in the knob comes loose, reinstall it in the interior notch with the small slit in the knob wall.

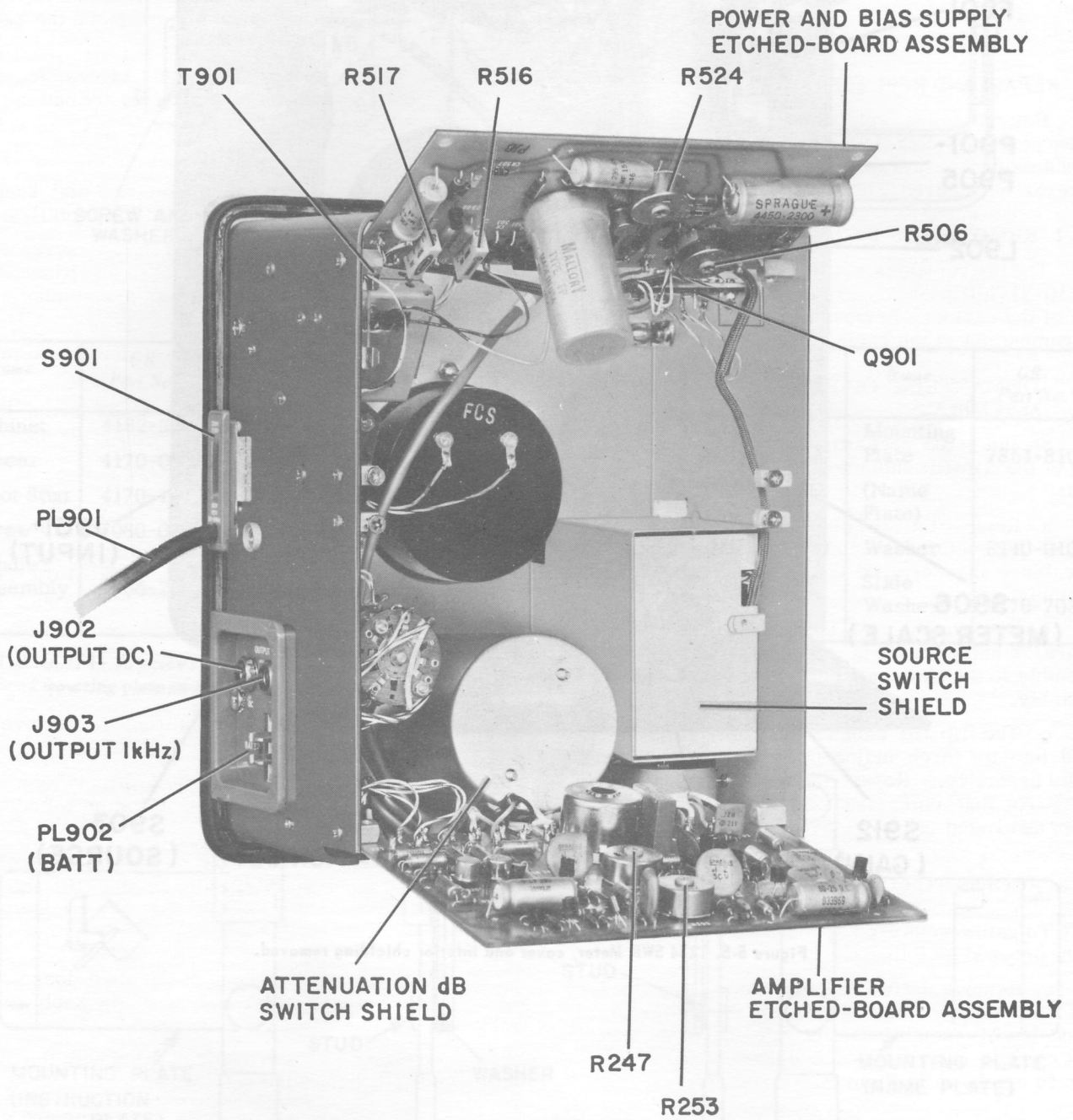

Figure 5-4. 1234 SWR Meter, cover removed and interior shielding shown in place.

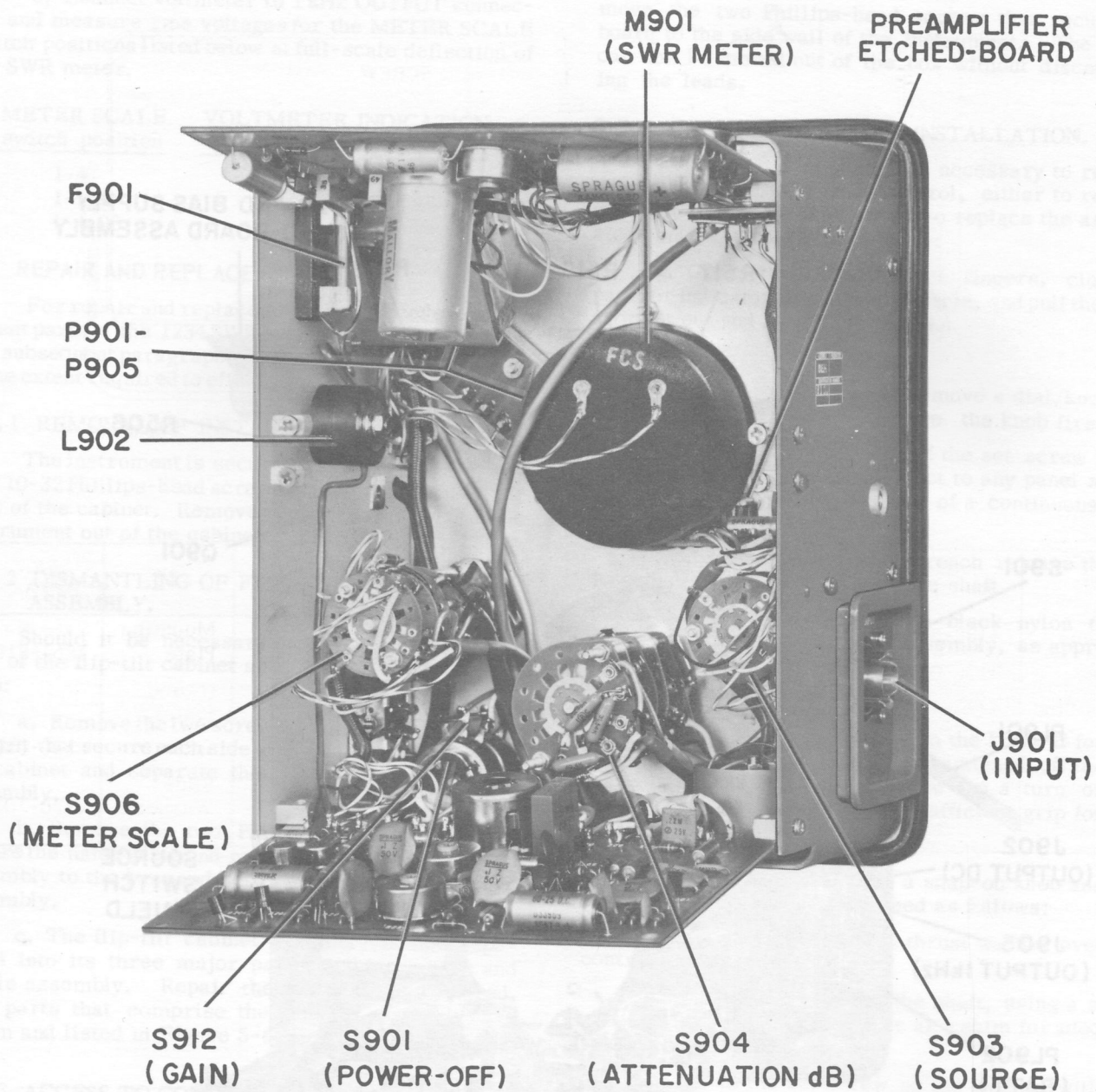
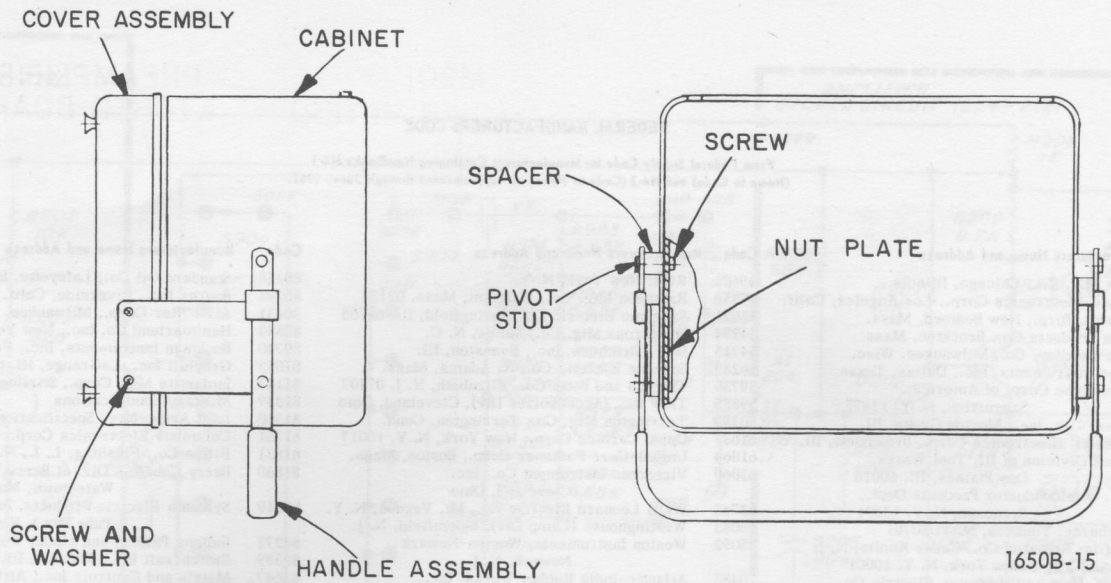

Figure 5-5. 1234 SWR Meter, cover and interior shielding removed.



(A)

Name	GR Part No.	Name	GR Part No.
Cabinet	4182-2003		
Spacer	4170-0900	Nut Plate	4170-1350
Pivot Stud	4170-1200	Screw	7080-1000
Screw*	7080-0700	Washer	8050-1500
Handle Assembly	1806-2200		

Name	GR. Part No.	Name	GR. Part No.
Mounting Plate	7860-3850	Mounting Plate	7864-8102
(Instruction Plate)		(Name Plate)	
Stud	4170-1100	Washer	8140-0102
Slide	4170-1271	Slide Washer	4170-7030
Handle	5360-0797		

\*Tighten 1/4 - 28 screws to 45-55 in. lbs torque.

\*\*Bend mounting plate to give 1/32 to 1/16 spacing, both sides.

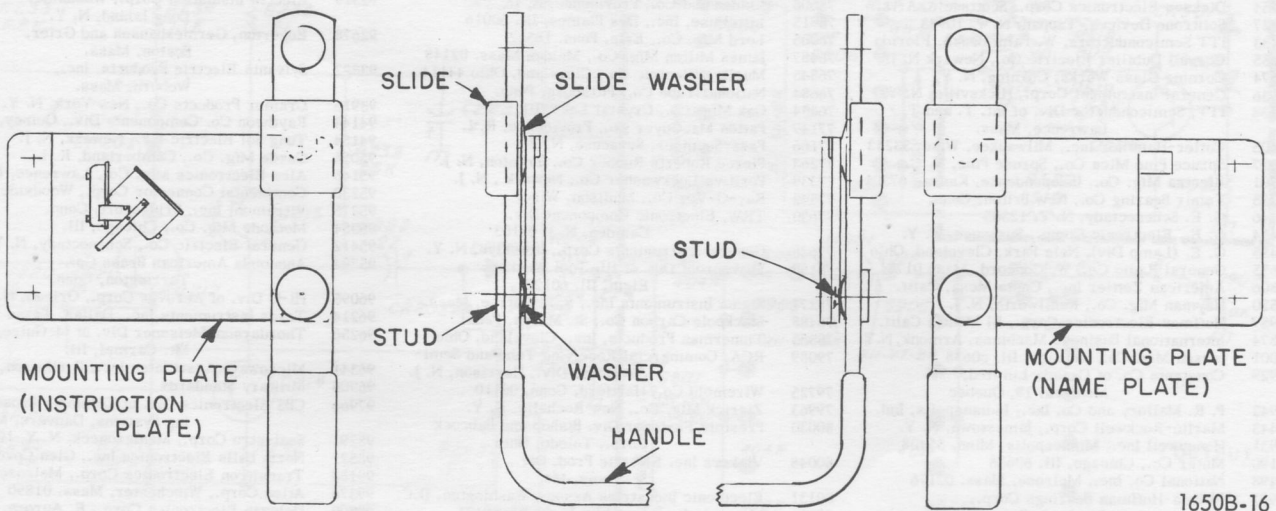

(B)

Figure 5-6. Flip-Tilt Cabinet detail parts.

FEDERAL MANUFACTURERS CODE

From Federal Supply Code for Manufacturers Cataloging Handbooks H4-1 (Name to Code) and H4-2 (Code to Name) as supplemented through June, 1967.

Code	Manufacturers Name and Address	Code	Manufacturers Name and Address	Code	Manufacturers Name and Address
00192	Jones Mfg. Co., Chicago, Illinois	49671	RCA, New York, N. Y.	80258	Standard Oil Co., Lafayette, Ind.
00194	Walsco Electronics Corp., Los Angeles, Calif.	49956	Raytheon Mfg. Co., Waltham, Mass. 02154	80294	Bourns Inc., Riverside, Calif. 92506
00656	Aerovox Corp., New Bedford, Mass.	53021	Sangamo Electric Co., Springfield, Ill. 62705	80431	Air Filter Corp., Milwaukee, Wisc. 53218
01009	Alden Products Co., Brockton, Mass.	54294	Shallcross Mfg. Co., Selma, N. C.	80583	Hammarlund Co. Inc., New York, N. Y.
01121	Allen-Bradley, Co., Milwaukee, Wisc.	54715	Shure Brothers, Inc., Evanston, Ill.	80740	Beckman Instruments, Inc., Fullerton, Calif.
01295	Texas Instruments, Inc., Dallas, Texas	56289	Sprague Electric Co., N. Adams, Mass.	81073	Grayhill Inc., LaGrange, Ill. 60525
02114	Ferrocube Corp. of America, Saugerties, N. Y. 12477	59730	Thomas and Betts Co., Elizabeth, N. J. 07207	81143	Isolantite Mfg. Corp., Stirling, N. J. 07980
02606	Fenwal Lab. Inc., Morton Grove, Ill.	59875	TRW Inc. (Accessories Div), Cleveland, Ohio	81349	Military Specifications
02660	Amphenol Electronics Corp., Broadview, Ill.	60399	Torrington Mfg. Co., Torrington, Conn.	81350	Joint Army-Navy Specifications
02768	Fastex Division of Ill. Tool Works, Des Plaines, Ill. 60016	61637	Union Carbide Corp., New York, N. Y. 10017	81751	Columbus Electronics Corp., Yonkers, N. Y.
03508	G. E. Semiconductor Products Dept., Syracuse, N. Y. 13201	61864	United-Carr Fastener Corp., Boston, Mass.	81831	Filton Co., Flushing, L. I., N. Y.
03636	Grayburne, Yonkers, N. Y. 10701	63060	Victoreen Instrument Co., Inc., Cleveland, Ohio	81860	Barry Controls Div. of Barry Wright Corp., Watertown, Mass.
03888	Pyrofilm Resistor Co., Cedar Knolls, N. J.	63743	Ward Leonard Electric Co., Mt. Vernon, N. Y.	82219	Sylvania Electric Products, Inc., (Electronic Tube Div.), Emporium, Penn.
03911	Clairex Corp., New York, N. Y. 10001	65083	Westinghouse (Lamp Div), Bloomfield, N. J.	82273	Indiana Pattern and Model Works, LaPort, Ind.
04009	Arrow, Hart and Hegeman Electric Co., Hartford, Conn. 06106	65092	Weston Instruments, Weston-Newark, Newark, N. J.	82389	Switchcraft Inc., Chicago, Ill. 60630
04713	Motorola Semi-Conduct Product, Phoenix, Ariz. 85008	70485	Atlantic-India Rubber Works, Inc., Chicago, Ill. 60607	82647	Metals and Controls Inc., Attleboro, Mass.
05170	Engineered Electronics Co., Inc., Santa Ana, Calif. 92702	70563	Amperite Co., Union City, N. J. 07087	82807	Milwaukee Resistor Co., Milwaukee, Wisc.
05624	Barber-Colman Co., Rockford, Ill. 61101	70903	Belden Mfg. Co., Chicago, Ill. 60644	83058	Carr Fastener Co., Cambridge, Mass.
05820	Wakefield Eng., Inc., Wakefield, Mass. 01880	71126	Bronson, Homer D., Co., Beacon Falls, Conn.	83186	Victory Engineering Corp (VECO), Springfield, N. J. 07081
07127	Eagle Signal Div. of E. W. Bliss Co., Baraboo, Wisc.	71294	Canfield, H. O. Co., Clifton Forge, Va. 24422	83361	Bearing Specialty Co., San Francisco, Calif.
07261	Avnet Corp., Culver City, Calif. 90230	71400	Bussman Mfg. Div. of McGraw Edison Co., St. Louis, Mo.	83587	Solar Electric Corp., Warren, Penn.
07263	Fairchild Camera and Instrument Corp., Mountain View, Calif.	71590	Centralab, Inc., Milwaukee, Wisc. 53212	83740	Union Carbide Corp., New York, N. Y. 10017
07387	Birtcher Corp., No. Los Angeles, Calif.	71666	Continental Carbon Co., Inc., New York, N. Y.	84411	TRW Capacitor Div., Ogallala, Nebr.
07595	American Semiconductor Corp., Arlington Heights, Ill. 60004	71707	Coto Coil Co. Inc., Providence, R. I.	84835	Lehigh Metal Products Corp., Cambridge, Mass. 02140
07828	Bodine Corp., Bridgeport, Conn. 06605	71744	Chicago Miniature Lamp Works, Chicago, Ill.	84971	TA Mfg. Corp., Los Angeles, Calif.
07829	Bodine Electric Co., Chicago, Ill. 60618	71785	Cinch Mfg. Co. and Howard B. Jones Div., Chicago, Ill. 60624	86577	Precision Metal Products of Malden Inc., Stoneham, Mass. 02180
07910	Continental Device Corp., Hawthorne, Calif.	71823	Darnell Corp., Ltd., Downey, Calif. 90241	86684	RCA (Electrical Component and Devices) Harrison, N. J.
07983	State Labs Inc., N. Y., N. Y. 10003	72136	Electro Motive Mfg. Co., Willmington, Conn.	88140	Cutler-Hammer Inc., Lincoln, Ill.
07999	Amphenol Corp., Borg Inst. Div., Delavan, Wisc. 53115	72259	Nytronics Inc., Berkeley Heights, N. J. 07922	88219	Gould Nat. Batteries Inc., Trenton, N. J.
08730	Vemaline Prod. Co., Franklin Lakes, N. J.	72699	Dialight Co., Brooklyn, N. Y. 11237	88419	Cornell Dubilier Electric Corp., Fuquay-Varina, N. C.
09213	General Electric Semiconductor, Buffalo, N. Y.	72765	General Instrument Corp., Capacitor Div., Newark, N. J. 07104	88627	K and G Mfg. Co., New York, N. Y.
09408	Star-Tronics Inc., Georgetown, Mass. 01830	72825	Drake Mfg. Co., Chicago, Ill. 60656	89482	Holtzer Cabot Corp., Boston, Mass.
09823	Burgess Battery Co., Freeport, Ill.	72962	Hugh H. Eby, Inc., Philadelphia, Penn. 19144	89665	United Transformer Co., Chicago, Ill.
09922	Burdym Corp., Norwalk, Conn. 06852	72982	Elastic Stop Nut Corp., Union, N. J. 07083	90201	Mallory Capacitor Co., Indianapolis, Ind.
11236	C.P.S. of Berne, Inc., Berne, Ind. 46711	73138	Erie Technological Products Inc., Erie, Penn.	90750	Westinghouse Electric Corp., Boston, Mass.
11599	Chandler Evans Corp., W. Hartford, Conn.	73445	Beckman, Inc., Fullerton, Calif. 92634	90952	Hardware Products Co., Reading, Penn. 19602
12498	Teledyn Inc., Crystallonics Div., Cambridge, Mass. 02140	73559	Amperex Electronics Co., Hicksville, N. Y.	91032	Continental Wire Corp., York, Penn. 17405
12672	RCA Commercial Receiving Tube and Semi- conductor Div., Woodridge, N.J.	73690	Carling Electric Co., W. Hartford, Conn.	91146	ITT Cannon Electric Inc., Salem, Mass.
12697	Clarostat Mfg. Co. Inc., Dover, N. H. 03820	73899	Elco Resistor Co., New York, N. Y.	91293	Johanson Mfg. Co., Bonton, N. J. 07005
12954	Dickson Electronics Corp., Scottsdale, Ariz.	74193	J. F. D. Electronics Corp., Brooklyn, N. Y.	91598	Chandler Co., Wethersfield, Conn. 06109
13327	Solitron Devices, Tappan, N. Y. 10983	74861	Heinemann Electric Co., Trenton, N. J.	91637	Dale Electronics Inc., Columbus, Nebr.
14433	ITT Semiconductors, W. Palm Beach, Florida	74970	Industrial Condenser Corp., Chicago, Ill.	91662	Elco Corp., Willow Grove, Penn.
14655	Cornell Dubilier Electric Co., Newark N. J.	75042	E. F. Johnson Co., Waseca, Minn. 56093	91719	General Instruments, Inc., Dallas, Texas
14674	Corning Glass Works, Corning, N. Y.	75382	IRC Inc., Philadelphia, Penn. 19108	91929	Honeywell Inc., Freeport, Ill.
14936	General Instrument Corp., Hicksville, N. Y.	75608	Kulka Electric Corp., Mt. Vernon, N. Y.	92519	Electra Insulation Corp., Woodside, Long Island, N. Y.
15238	ITT, Semiconductor Div. of Int. T. and T., Lawrence, Mass.	75915	Linden and Co., Providence, R. I.	92678	Edgerton, Germeshausen and Grier, Boston, Mass.
15605	Cutler-Hammer Inc., Milwaukee, Wisc. 53233	76005	Littelfuse, Inc., Des Plaines, Ill. 60016	93332	Sylvania Electric Products, Inc., Woburn, Mass.
16037	Spruce Pine Mica Co., Spruce Pine, N. C.	76487	Lord Mfg. Co., Erie, Penn. 16512	93916	Cramer Products Co., New York, N. Y. 10013
19701	Electra Mfg. Co., Independence, Kansas 67301	76545	James Millen Mfg. Co., Malden, Mass. 02148	94144	Raytheon Co. Components Div., Quincy, Mass.
21335	Fafnir Bearing Co., New Briton, Conn.	76545	Mueller Electric Co., Cleveland, Ohio 44114	94154	Tung Sol Electric Inc., Newark, N. J.
24446	G. E. Schenectady, N. Y. 12305	76684	National Tube Co., Pittsburg, Penn.	95076	Garde Mfg. Co., Cumberland, R. I.
24454	G. E., Electronic Comp., Syracuse, N. Y.	76854	Oak Mfg. Co., Crystal Lake, Ill.	95146	Alco Electronics Mfg. Co., Lawrence, Mass.
24455	G. E. (Lamp Div), Nela Park, Cleveland, Ohio	77147	Patton MacGuyre Co., Providence, R. I.	95238	Continental Connector Corp., Woodside, N. Y.
24655	General Radio Co., W. Concord, Mass 01781	77166	Pass-Seymour, Syracuse, N. Y.	95275	Vitramon, Inc., Bridgeport, Conn.
26806	American Zettler Inc., Costa Mesa, Calif.	77263	Pierce Roberts Rubber Co., Trenton, N. J.	95354	Methode Mfg. Co., Chicago, Ill.
28520	Hayman Mfg. Co., Kenilworth, N. J.	77339	Positive Lockwasher Co., Newark, N. Y.	95412	General Electric Co., Schenectady, N. Y.
28959	Hoffman Electronics Corp., El Monte, Calif.	77542	Ray-O-Vac Co., Madison, Wisc.	95794	Ansonda American Brass Co., Torrington, Conn.
30874	International Business Machines, Armonk, N.Y.	77630	TRW, Electronic Component Div., Camden, N. J. 08103	96095	Hi-Q Div. of Aerovox Corp., Orlean, N. Y.
32001	Jensen Mfg. Co., Chicago, Ill. 60638	77638	General Instruments Corp., Brooklyn, N. Y.	96214	Texas Instruments Inc., Dallas, Texas 75209
35929	Constanta Co. of Canada Limited, Montreal 19, Quebec	78189	Shakeproof Div. of Ill. Tool Works, Elgin, Ill. 60120	96256	Thordarson-Meissner Div. of McGuire, Mt. Carmel, Ill.
37942	P. R. Mallory and Co. Inc., Indianapolis, Ind.	78277	Sigma Instruments Inc., S. Braintree, Mass.	96341	Microwave Associates Inc., Burlington, Mass.
38443	Marlin-Rockwell Corp., Jamestown, N. Y.	78488	Stackpole Carbon Co., St. Marys, Penn.	96906	Military Standards
40931	Honeywell Inc., Minneapolis, Minn. 55408	78553	Tinnerman Products, Inc., Cleveland, Ohio	97966	CBS Electronics Div. of Columbia Broadcast- ing Systems, Danvers, Mass.
42190	Muter Co., Chicago, Ill. 60638	79089	RCA, Commercial Receiving Tube and Semi- conductor Div., Harrison, N. J.	98291	Sealectro Corp., Mamaroneck, N. Y. 10544
42498	National Co. Inc., Melrose, Mass. 02176	79725	Wiremold Co., Hartford, Conn. 06110	98821	North Hills Electronics Inc., Glen Cove, N. Y.
43991	Norma-Hoffman Bearings Corp., Stanford, Conn. 06904	79963	Zierick Mfg. Co., New Rochelle, N. Y.	99180	Transitron Electronics Corp., Melrose, Mass.
		80030	Prestole Fastener Div. Bishop and Babcock Corp., Toledo, Ohio	99378	Atlee Corp., Winchester, Mass. 01890
		80048	Vickers Inc. Electric Prod. Div., St. Louis, Mo.	99800	Delevan Electronics Corp., E. Aurora, N. Y.
		80131	Electronic Industries Assoc., Washington, D.C.		
		80211	Motorola Inc., Franklin Park, Ill. 60131		

- NOTE UNLESS SPECIFIED
1. POSITION OF ROTARY SWITCHES SHOWN COUNTERCLOCKWISE.
  2. CONTACT NUMBERING OF SWITCHES EXPLAINED ON SEPARATE SHEET SUPPLIED IN INSTRUCTION BOOK.
  3. REFER TO SERVICE NOTES IN INSTRUCTION BOOK FOR VOLTAGES APPEARING ON DIAGRAM.
  4. RESISTORS 1/4 WATT.
  5. RESISTANCE IN OHMS  
K - 1000 OHMS M - 1 MEGOHM
  6. CAPACITANCE VALUES ONE AND OVER IN PICOFARADS, LESS THAN ONE IN MICROFARADS.
  7. ○ KNOB CONTROL
  8. ⊗ SCREWDRIVER CONTROL
  9. AT - ANCHOR TERMINAL
  10. TP - TEST POINT

TRANSISTORS - BOTTOM VIEW

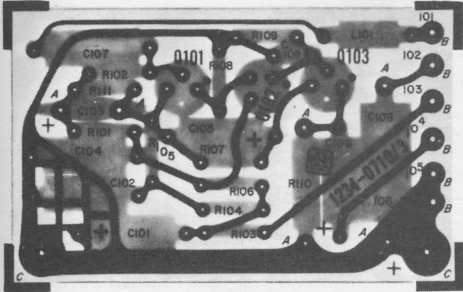
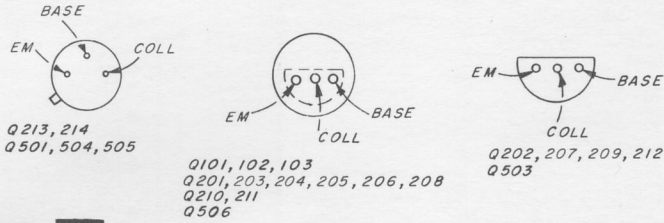

Figure 5-7. Etched-board assembly for preamplifier circuit (P/N 1234-2711).

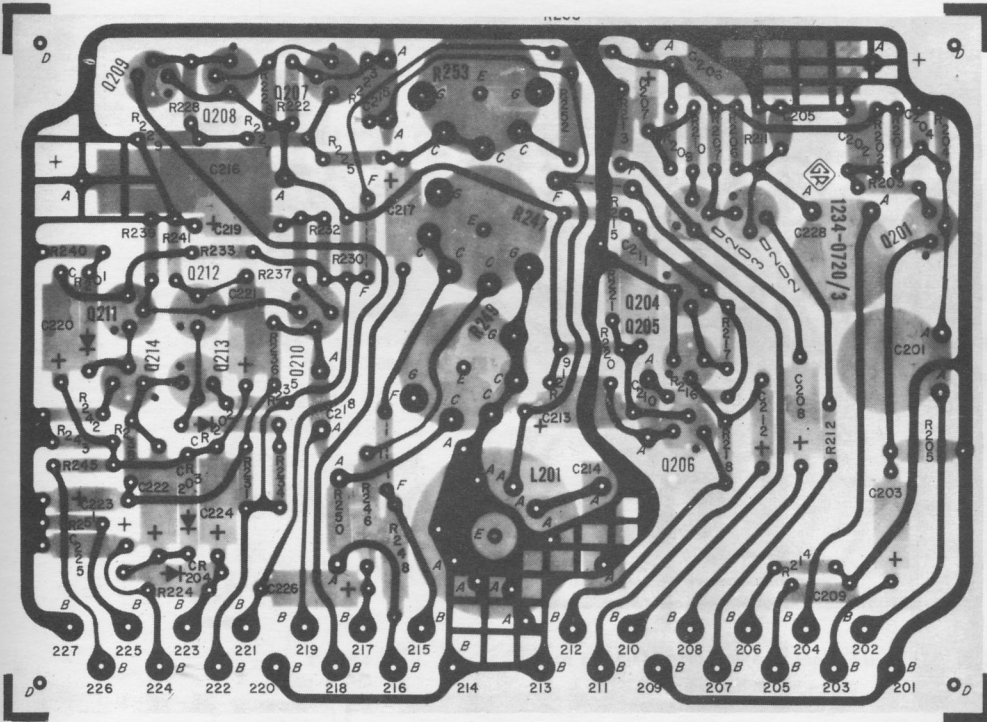
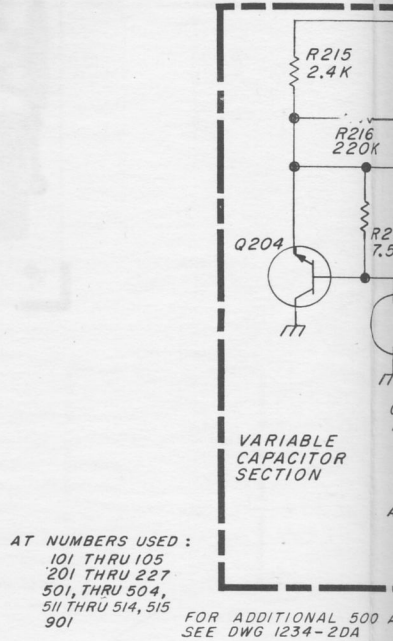
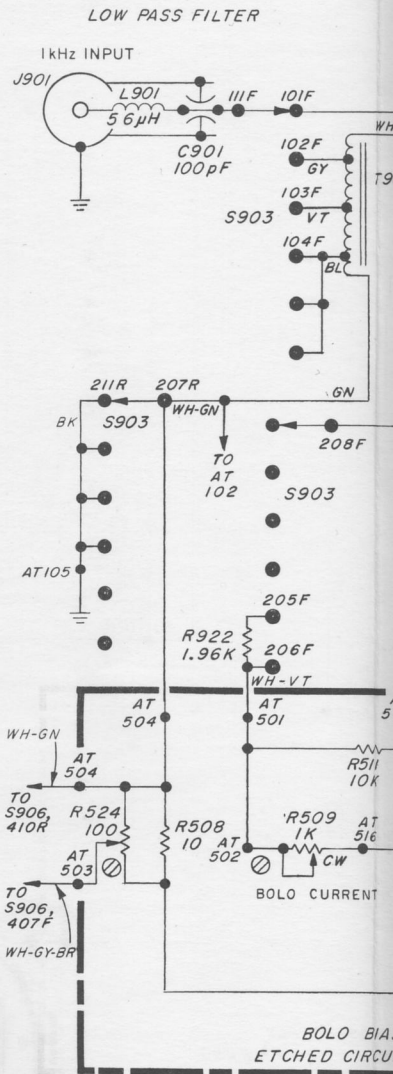
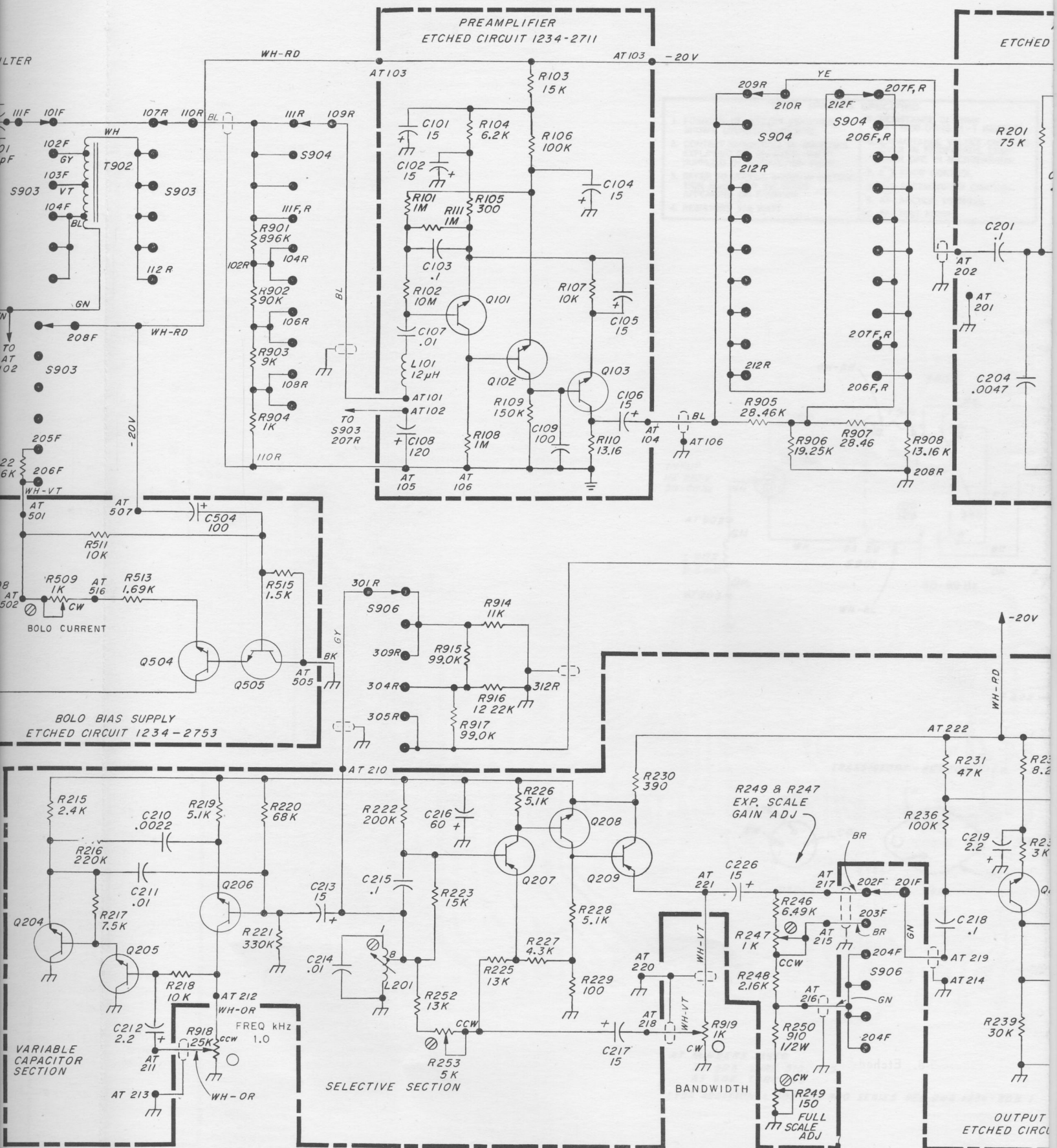

Figure 5-8. Etched-board assembly for amplifier circuits (P/N 1234-2721).

NOTE: The number appearing on the foil side is not the part number.  
The dot on the foil at the transistor socket indicates the collector lead.







FOR ADDITIONAL 500 AND 900 SERIES, SEE DWG 1234-2DA

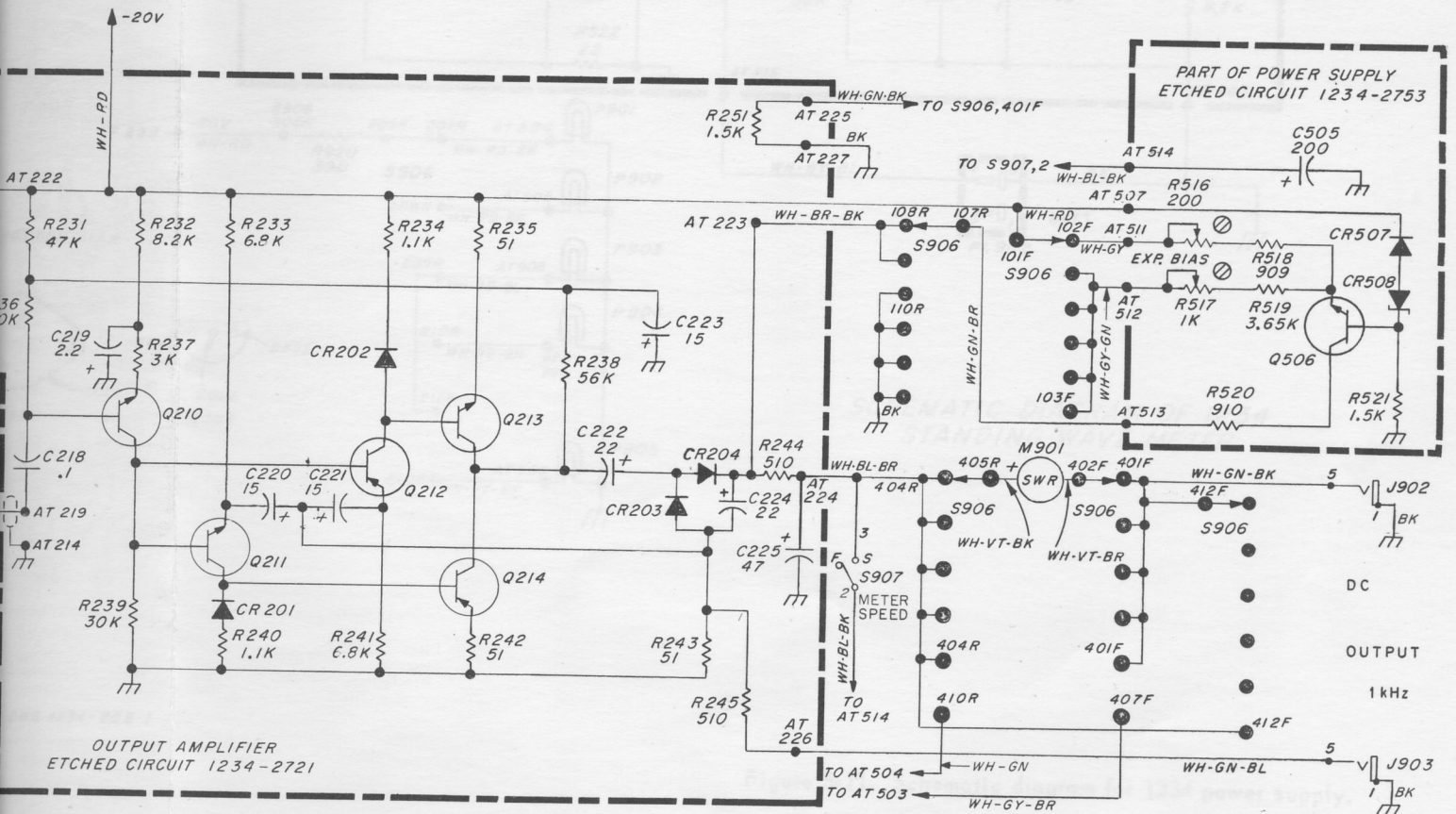
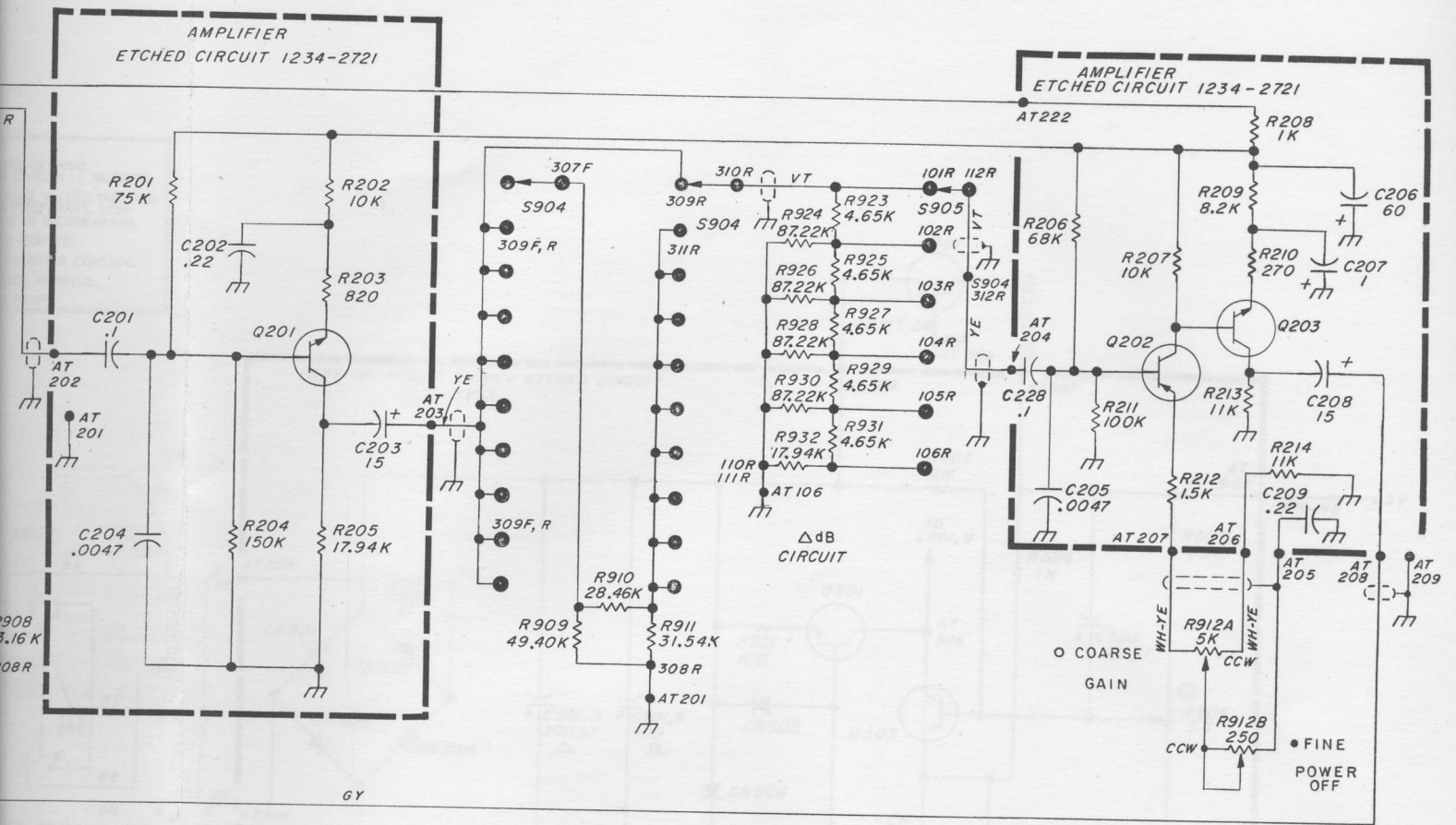

Figure 5-9. Overall schematic diagram of 1234 (less power supply).

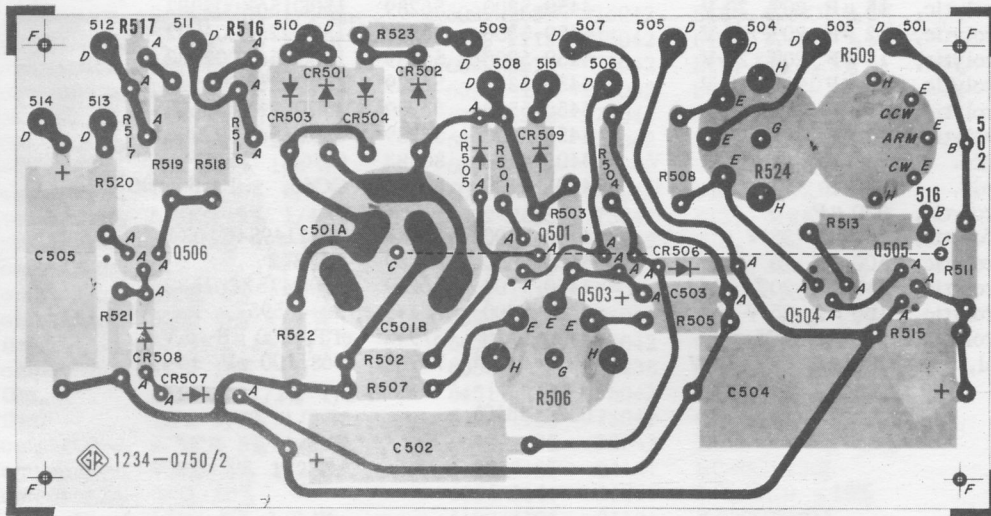

Figure 5-10. Etched-board assembly for power supply circuit (P/N 1234-2753).

NOTE: The number appearing on the foil side is not the part number.  
The dot on the foil at the transistor socket indicates the collector lead.



## PARTS LIST

Ref. Desig.	Description	GR Part No.	FMC	Mfg. Part No.	Fed. Stock No.
<b>CAPACITORS</b>					
C101	Electrolytic, 15 $\mu$ F 20% 20 V	4450-5200	56289	150D156X0020B2	5910-855-6335
C102	Electrolytic, 15 $\mu$ F 20% 20 V	4450-5200	56289	150D156X0020B2	5910-855-6335
C103	Ceramic, 1 $\mu$ F +80-20 50 V	4403-4100	80131	CC63, .1 $\mu$ F +80-20%	5910-811-4788
C104	Electrolytic, 15 $\mu$ F 20% 20 V	4450-5200	56289	150D156X0020B2	5910-855-6335
C105	Electrolytic, 15 $\mu$ F 20% 20 V	4450-5200	56289	150D156X0020B2	5910-855-6335
C106	Electrolytic, 15 $\mu$ F 20% 20 V	4450-5200	56289	150D156X0020B2	5910-855-6335
C107	Plastic, .01 $\mu$ F 10% 100 V	4860-7750	84411	663UW, .01 $\mu$ F $\pm$ 10%	
C108	Electrolytic, 120 $\mu$ F 20% 10 V	4450-5616	56289	150D127X0010R2	
C109	Ceramic, 100 $\rho$ F +80-20% 500 V	4404-1109	72982	831, 100 $\rho$ F +80-20%	
C201	Ceramic, .1 $\mu$ F +80-20% 50 V	4403-4100	80131	CC63, .1 $\mu$ F +80-20%	5910-811-4788
C202	Ceramic, .22 $\mu$ F 20% 25 V	4400-2052	80183	5C13, .22 $\mu$ F $\pm$ 20%	5910-974-5694
C203	Electrolytic, 15 $\mu$ F 20% 20 V	4450-5200	56289	150D156X0020B2	5910-855-6335
C204	Ceramic, .0047 $\mu$ F +80-20% 500 V	4405-2479	72982	801, .0047 $\mu$ F +80-20%	
C205	Ceramic, .0047 $\mu$ F +80-20% 500 V	4405-2479	72982	801, .0047 $\mu$ F +80-20%	
C206	Electrolytic, 60 $\mu$ F 25 V	4450-2900	80183	D17872	5910-799-9280
C207	Electrolytic, 1 $\mu$ F 10% 35 V	4450-4301	56289	150D105X9035A2	
C208	Electrolytic, 15 $\mu$ F 20% 20 V	4450-5200	56289	150D156X0020B2	5910-855-6335
C209	Ceramic, .22 $\mu$ F 20% 25 V	4400-2052	80183	5C13, .22 $\mu$ F $\pm$ 20%	5910-974-5694
C210	Ceramic, .0022 $\mu$ F 10% 500 V	4406-2228	72982	811, .0022 $\mu$ F $\pm$ 10%	
C211	Plastic, .01 $\mu$ F 5% 100 V	4860-7755	84411	663UW, .01 $\mu$ F $\pm$ 5%	
C212	Electrolytic, 2.2 $\mu$ F 20% 20 V	4450-4500	56289	150D225X0020A2	5910-976-4604
C213	Electrolytic, 15 $\mu$ F 20% 20 V	4450-5200	56289	150D156X0020B2	5910-855-6335
C214	Mica, .01 $\mu$ F 1% 500 V	4560-0300	14655	1A, .01 $\mu$ F $\pm$ 1%	5910-843-2984
C215	Ceramic, .1 $\mu$ F +80-20% 50 V	4403-4100	80131	CC63 .1 $\mu$ F +80-20%	5910-811-4788
C216	Electrolytic, 60 $\mu$ F 25 V	4450-2900	80183	D17872	5910-799-9280
C217	Electrolytic, 15 $\mu$ F 20% 20 V	4450-5200	56289	150D156X0020B2	5910-855-6335
C218	Ceramic, .1 $\mu$ F +80-20% 50 V	4403-4100	80131	.1 $\mu$ F +80-20%	5910-811-4788
C219	Electrolytic, 2.2 $\mu$ F 20% 20 V	4450-4500	56289	150D225X0020A2	5910-976-4604
C220	Electrolytic, 15 $\mu$ F 20% 20 V	4450-5200	56289	150D156X0020B2	5910-855-6335
C221	Electrolytic, 15 $\mu$ F 20% 20 V	4450-5200	56289	150D156X0020B2	5910-855-6335
C222	Electrolytic, 22 $\mu$ F 20% 15 V	4450-5300	56289	150D226X0015B2	5910-752-4270
C223	Electrolytic, 15 $\mu$ F 20% 20 V	4450-5200	56289	150D156X0020B2	5910-855-6335
C224	Electrolytic, 22 $\mu$ F 20% 15 V	4450-5300	56289	150D226X0015B2	5910-752-4270
C225	Electrolytic, 47 $\mu$ F 20% 6 V	4450-5500	56289	150D476X0006B2	5910-752-4185
C226	Electrolytic, 15 $\mu$ F 20% 20 V	4450-5200	56289	150D156X0020B2	5910-855-6335
C227	Ceramic, .1 $\mu$ F +80-20% 50 V	4403-4100	80183	CC63, .1 $\mu$ F +80-20%	5910-811-4788
C228	Ceramic, .1 $\mu$ F +80-20% 50 V	4403-4100	80183	CC63, .1 $\mu$ F +80-20%	5910-811-4788
C501A	Electrolytic, 300 $\mu$ F				
C501B	Electrolytic, 300 $\mu$ F 35 V	4450-2400	37942	2021149S4C10X1	5910-822-2691
C502	Electrolytic, 100 $\mu$ F 15 V	4450-2800	56289	D17872	5910-034-5368
C503	Electrolytic, 4.7 $\mu$ F 20% 10 V	4450-4700	56289	150D475X0015B2	5910-813-8160
C504	Electrolytic, 100 $\mu$ F 25 V	4450-2300	76149	20-40595	5910-799-9284
C505	Electrolytic, 200 $\mu$ F 6 V	4450-2610	37942	TT, 200 $\mu$ F 6 V	5910-945-1836
C901	Special, 100 $\rho$ F 20% 10 V	4920-0250*	72982	668, 100 $\rho$ F $\pm$ 20%	5910-562-7490
		(Part of 0874-4310)			

### RESISTORS

R101	Composition, 1M $\Omega$ 5% 1/4 W	6099-5105	75042	BTS, 1M $\Omega$ $\pm$ 5%	
R102	Composition, 10M $\Omega$ 5% 1/4 W	6099-6105	75042	BTS, 10M $\Omega$ $\pm$ 5%	
R103	Composition, 15K $\Omega$ 5% 1/4 W	6099-3155	75042	BTS, 15K $\Omega$ $\pm$ 5%	
R104	Composition, 6.2K $\Omega$ 5% 1/4 W	6099-2625	75042	BTS, 6.2K $\Omega$ $\pm$ 5%	
R105	Composition, 300 $\Omega$ 5% 1/4 W	6099-1305	75042	BTS, 300 $\Omega$ $\pm$ 5%	5905-279-5481
R106	Composition, 100K $\Omega$ 5% 1/4 W	6099-4105	75042	BTS, 100K $\Omega$ $\pm$ 5%	
R107	Composition, 10K $\Omega$ 5% 1/4 W	6099-3105	75042	BTS, 10K $\Omega$ $\pm$ 5%	
R108	Composition, 1M $\Omega$ 5% 1/4 W	6099-5105	75042	BTS, 1M $\Omega$ $\pm$ 5%	
R109	Composition, 150K $\Omega$ 5% 1/4 W	6099-4155	75042	BTS, 150K $\Omega$ $\pm$ 5%	
R110	Film, 13.16K $\Omega$ 1/2% 1/2 W	6451-2136	75042	CEC-TO, 13.16K $\Omega$ $\pm$ 1/2%	
R201	Composition, 75K $\Omega$ 5% 1/4 W	6099-3755	75042	BTS, 75K $\Omega$ $\pm$ 5%	
R202	Composition, 10K $\Omega$ 5% 1/4 W	6099-3105	75042	BTS, 10K $\Omega$ $\pm$ 5%	

## PARTS LIST (Cont)

Ref. Desig.	Description	GR Part No.	FMC	Mfg. Part No.	Fed. Stock No.
<b>RESISTORS (Cont)</b>					
R203	Composition, 820Ω 5% 1/4 W	6099-1825	75042	BTS, 820Ω ±5%	
R204	Composition, 150KΩ 5% 1/4 W	6099-4155	75042	BTS, 150KΩ ±5%	
R205	Film, 17.94Ω 1/2% 1/8 W	6251-2179	75042	CEA-TO, 17.94Ω ±1/2%	
R206	Composition, 68KΩ 5% 1/4 W	6099-3685	75042	BTS, 68KΩ ±5%	
R207	Composition, 10KΩ 5% 1/4 W	6099-3105	75042	BTS, 10KΩ ±5%	
R208	Composition, 1KΩ 5% 1/4 W	6099-2105	75042	BTS, 1KΩ ±5%	
R209	Composition, 8.2KΩ 5% 1/4 W	6099-2825	75042	BTS, 8.2KΩ ±5%	
R210	Composition, 270Ω 5% 1/4 W	6099-1275	75042	BTS, 270Ω ±5%	
R211	Composition, 100KΩ 5% 1/4 W	6099-4105	75042	BTS, 100KΩ ±5%	
R212	Composition, 1.5KΩ 5% 1/4 W	6099-2155	75042	BTS, 1.5KΩ ±5%	
R213	Film, 11KΩ 1/2% 1/8 W	6251-2110	75042	CEA-TO, 11KΩ ±1/2%	
R214	Composition, 11KΩ 5% 1/4 W	6099-3115	75042	BTS, 11KΩ ±5%	
R215	Composition, 2.4KΩ 5% 1/4 W	6099-2245	75042	BTS, 2.4KΩ ±5%	
R216	Composition, 220KΩ 5% 1/4 W	6099-4225	75042	BTS, 220KΩ ±5%	
R217	Composition, 7.5KΩ 5% 1/4 W	6099-2755	75042	BTS, 7.5KΩ ±5%	
R218	Composition, 10KΩ 5% 1/4 W	6099-3105	75042	BTS, 10KΩ ±5%	
R219	Composition, 5.1KΩ 5% 1/4 W	6099-2515	75042	BTS, 5.1KΩ ±5%	5905-279-4623
R220	Composition, 68KΩ 5% 1/4 W	6099-3685	75042	BTS, 68KΩ ±5%	
R221	Composition, 330KΩ 5% 1/4 W	6099-4335	75042	BTS, 330KΩ ±5%	
R222	Composition, 200KΩ 5% 1/4 W	6099-4205	75042	BTS, 200KΩ ±5%	
R223	Composition, 15KΩ 5% 1/4 W	6099-3155	75042	BTS, 15KΩ ±5%	
R225	Composition, 13KΩ 5% 1/4 W	6099-3135	75042	BTS, 13KΩ ±5%	
R226	Composition, 5.1KΩ 5% 1/4 W	6099-2515	75042	BTS, 5.1KΩ ±5%	5905-279-4623
R227	Composition, 4.3KΩ 5% 1/4 W	6099-2435	75042	BTS, 4.3KΩ ±5%	
R228	Composition, 5.1KΩ 5% 1/4 W	6099-2515	75042	BTS, 5.1KΩ ±5%	5905-279-4623
R229	Composition, 100Ω 5% 1/4 W	6099-1105	75042	BTS, 100Ω ±5%	
R230	Composition, 390Ω 5% 1/4 W	6099-1395	75042	BTS, 390Ω ±5%	
R231	Composition, 47KΩ 5% 1/4 W	6099-3475	75042	BTS, 47KΩ ±5%	
R232	Composition, 8.2KΩ 5% 1/4 W	6099-2825	75042	BTS, 8.2KΩ ±5%	
R233	Composition, 6.8KΩ 5% 1/4 W	6099-2685	75042	BTS, 6.8KΩ ±5%	
R234	Composition, 1.1KΩ 5% 1/4 W	6099-2115	75042	BTS, 1.1KΩ ±5%	
R235	Composition, 51Ω 5% 1/4 W	6099-0515	75042	BTS, 51Ω ±5%	
R236	Composition, 100KΩ 5% 1/4 W	6099-4105	75042	BTS, 100KΩ ±5%	
R237	Composition, 3KΩ 5% 1/4 W	6099-2305	75042	BTS, 3KΩ ±5%	
R238	Composition, 56KΩ 5% 1/4 W	6099-3565	75042	BTS, 56KΩ ±5%	
R239	Composition, 30KΩ 5% 1/4 W	6099-3305	75042	BTS, 30KΩ ±5%	
R240	Composition, 1.1KΩ 5% 1/4 W	6099-2115	75042	BTS, 1.1KΩ ±5%	
R241	Composition, 6.8KΩ 5% 1/4 W	6099-2685	75042	BTS, 6.8KΩ ±5%	
R242	Composition, 51Ω 5% 1/4 W	6099-0515	75042	BTS, 51Ω ±5%	
R243	Composition, 51Ω 5% 1/4 W	6099-0515	75042	BTS, 51Ω ±5%	
R244	Composition, 510Ω 5% 1/4 W	6099-1515	75042	BTS, 510Ω ±5%	
R245	Composition, 510Ω 5% 1/4 W	6099-1515	75042	BTS, 510Ω ±5%	
R246	Film, 6.49KΩ 1% 1/2 W	6450-1649	75042	CEC-TO, 6.49KΩ ±5%	
R247	Composition, 1KΩ 10%	6056-0138	11236	115, 1KΩ ±10%	
R248	Film, 2.16KΩ 1/2% 1/2 W	6451-1216	75042	CEC-TO, 2.16KΩ	
R250	Film, 1KΩ 1/2% 1/2 W	6451-1100	75042	CEC-TO, 1KΩ ±1/2%	
R251	Composition, 1.5KΩ 5% 1/4 W	6099-2155	75042	BTS, 1.5KΩ ±5%	
R252	Composition, 15KΩ 5% 1/2 W	6100-3155	01121	RC20GF153J	5905-279-2616
R253	Composition, 3KΩ 10%	6056-0141	11236	115, 3KΩ ±10%	
R501	Composition, 100Ω 5% 1/2 W	6100-1105	01121	RC20GF101J	5905-190-8889
R502	Composition, 56KΩ 5% 1/2 W	6100-3565	01121	RC20GF563J	5905-171-1986
R503	Composition, 2MΩ 5% 1/2 W	6100-5205	01121	RC20GF205J	5905-279-1875
R504	Composition, 1KΩ 5% 1/2 W	6100-2105	01121	RC20GF102J	5905-195-6806
R505	Composition, 5.1KΩ 5% 1/2 W	6100-2515	01121	RC20GF512J	5905-279-2019
R506	Composition, 3KΩ 10%	6056-0141	11236	115, 3KΩ ±10%	
R507	Composition, 8.2KΩ 5% 1/2 W	6100-2825	01121	RC20GF822J	5905-299-1971
R508	Composition, 10Ω 5% 1/2 W	6100-0105	01121	RC20GF100J	5905-190-8883
R509	Composition, 1KΩ 10%	6056-0138	11236	115, 1KΩ ±10%	
R511	Composition, 10KΩ 5% 1/2 W	6100-3105	01121	RC20GF103J	5905-185-8510
R513	Film, 1.69KΩ 1% 1/2 W	6450-1169	75042	CEC-TO, 1.69KΩ ±1%	
R515	Composition, 1.5KΩ 5% 1/2 W	6100-2155	01121	RC20GF152J	5905-841-7461
R516	Composition, 200Ω 10%	6051-1209	96791	2600PC, 200Ω ±10%	

## PARTS LIST (Cont)

Ref. Desig.	Description	GR Part. No.	FMC	Mfg. Part No.	Fed. Stock No.
<b>RESISTORS (Cont)</b>					
R517	Composition, 1K $\Omega$ 10%	6051-2109	02660	2600PC, 1K $\Omega$ $\pm$ 10%	
R518	Film, 909 $\Omega$ 1% 1/2 W	6450-0909	75042	CEC, 909 $\Omega$ $\pm$ 1%	
R519	Film, 3.65K $\Omega$ 1% 1/2 W	6450-1365	75042	CEC, 3.65K $\Omega$ $\pm$ 1%	
R520	Composition, 910 $\Omega$ 5% 1/4 W	6100-1915	01121	RC20GF911J	5905-279-3509
R521	Composition, 1.5K $\Omega$ 5% 1/2 W	6100-2155	01121	RC20GF152J	5905-841-7461
R522	Composition, 22 $\Omega$ 5% 1/4 W	6100-0225	01121	RC20GF220J	5905-279-3519
R523	Composition, 10 $\Omega$ 5% 1/2 W	6100-0105	01121	RC20GF100J	5905-190-8883
R524	Composition, 100 $\Omega$ 10%	6056-0132	11236	115, 100 $\Omega$ $\pm$ 10%	
R901	Film, 896K $\Omega$ 1/2% 1/2 W	6451-3896	75042	CEC-TO, 896K $\Omega$ $\pm$ 1/2 %	
R902	Film, 90K $\Omega$ 1/2% 1/2 W	6451-2900	75042	CEC-TO, 90K $\Omega$ $\pm$ 1/2%	
R903	Film, 9K $\Omega$ 1/2% 1/2 W	6451-1900	75042	CEC-TO, 9K $\Omega$ $\pm$ 1/2 %	
R904	Film, 1K $\Omega$ 1/2% 1/2 W	6451-1100	75042	CEC-TO, 1K $\Omega$ $\pm$ 1/2%	
R905	Film, 28.46K $\Omega$ 1/2% 1/2 W	6451-2284	75042	CEC-TO, 28.46K $\Omega$ $\pm$ 1/2%	
R906	Film, 19.25K $\Omega$ 1/2% 1/2 W	6451-2192	75042	CEC-TO, 19.25K $\Omega$ $\pm$ 1/2%	
R907	Film, 28.46K $\Omega$ 1/2% 1/2 W	6451-2284	75042	CEC-TO, 28.46K $\Omega$ $\pm$ 1/2%	
R908	Film, 13.16K $\Omega$ 1/2% 1/2 W	6451-2136	75042	CEC-TO, 13.16K $\Omega$ $\pm$ 1/2%	
R909	Film, 49.40K $\Omega$ 1/2% 1/2 W	6451-2494	75042	CEC-TO, 49.40K $\Omega$ $\pm$ 1/2%	
R910	Film, 28.46K $\Omega$ 1/2% 1/2 W	6451-2284	75042	CEC-TO, 28.46K $\Omega$ $\pm$ 1/2%	
R911	Film, 31.54K $\Omega$ 1/2% 1/2 W	6451-2315	75042	CEC-TO, 31.54K $\Omega$ $\pm$ 1/2%	
R912A	Comp. Dual, 5K $\Omega$	6045-2020	01121	JJ, 5K $\Omega$ /250 $\Omega$	
R912B	Comp. Dual, 250 $\Omega$	6045-2020			
R914	Film, 11K $\Omega$ 1/2% 1/8 W	6251-2110	75042	CEA-TO, 11K $\Omega$ $\pm$ 1/2%	
R915	Film, 99K $\Omega$ 1/2% 1/8 W	6251-2990	75042	CEA-TO, 99K $\Omega$ $\pm$ 1/2%	
R916	Film, 12.22K $\Omega$ 1/2% 1/8 W	6251-2122	75042	CEA-TO, 12.22K $\Omega$ $\pm$ 1/2%	
R917	Film, 99K $\Omega$ 1/2% 1/8 W	6251-2990	75042	CEA-TO, 99K $\Omega$ $\pm$ 1/2%	
R918	Composition, 25K $\Omega$ 10%	6010-1100	01121	JU, 25K $\Omega$ $\pm$ 10%	5905-857-7295
R919	Composition, 1K $\Omega$ 10%	6010-0400	01121	JU, 1K $\Omega$ $\pm$ 10%	
R920	Composition, 390 $\Omega$ 5% 1/4 W	6100-1395	01121	RC20GF391J	5905-279-1890
R922	Film, 1.96K $\Omega$ 1% 1/2 W	6450-1196	75042	CEC-TO, 1.96K $\Omega$ $\pm$ 1%	
R923	Film, 4.65K $\Omega$ 1/2% 1/8 W	6251-1465	75042	CEA-TO, 4.65K $\Omega$ $\pm$ 1/2%	
R924	Film, 87.22K $\Omega$ 1/2% 1/8 W	6251-2872	75042	CEA-TO, 87.22K $\Omega$ $\pm$ 1/2%	
R925	Film, 4.65K $\Omega$ 1/2% 1/8 W	6251-1465	75042	CEA-TO, 4.65K $\Omega$ $\pm$ 1/2%	
R926	Film, 87.22K $\Omega$ 1/2% 1/8 W	6251-2872	75042	CEA-TO, 87.22K $\Omega$ $\pm$ 1/2%	
R927	Film, 4.65K $\Omega$ 1/2% 1/8 W	6251-1465	75042	CEA-TO, 4.65K $\Omega$ $\pm$ 1/2%	
R928	Film, 87.22K $\Omega$ 1/2% 1/8 W	6251-2872	75042	CEA-TO, 87.22K $\Omega$ $\pm$ 1/2%	
R929	Film, 4.65K $\Omega$ 1/2% 1/8 W	6251-1465	75042	CEA-TO, 4.65K $\Omega$ $\pm$ 1/2%	
R930	Film, 87.22K $\Omega$ 1/2% 1/8 W	6251-2872	75042	CEA-TO, 87.22K $\Omega$ $\pm$ 1/2%	
R931	Film, 4.65K $\Omega$ 1/2% 1/8 W	6251-1465	75042	CEA-TO, 4.65K $\Omega$ $\pm$ 1/2%	
R932	Film, 17.94K $\Omega$ 1/2% 1/8 W	6251-2179	75042	CEA-TO, 17.94K $\Omega$ $\pm$ 1/2%	

### TRANSISTORS

Q101	Type 2N3391A	8210-1083	24454	4JX16A733	
Q102	Type 2N3416	8210-1047	24446	2N3414	5961-989-2749
Q103	Type 2N3416	8210-1047	24446	2N3414	5961-989-2749
Q201	Type 2N3416	8210-1047	24446	2N3414	5961-989-2749
Q202	Type 2N3702	8210-1106	01295	2N3702	
Q203	Type 2N3416	8210-1047	24446	2N3414	5961-989-2749
Q204	Type 2N3416	8210-1047	24446	2N3414	5961-989-2749
Q205	Type 2N3416	8210-1047	24446	2N3414	5961-989-2749
Q206	Type 2N3416	8210-1047	24446	2N3414	5961-989-2749
Q207	Type 2N3702	8210-1106	01295	2N3702	
Q208	Type 2N3416	8210-1047	24446	2N3414	5961-989-2749
Q209	Type 2N3702	8210-1106	01295	2N3702	
Q210	Type 2N3416	8210-1047	24446	2N3414	5961-989-2749
Q211	Type 2N3416	8210-1047	24446	2N3414	5961-989-2749
Q212	Type 2N3702	8210-1106	01295	2N3702	
Q213	Type 2N697	8210-1040	82219	2N697	5961-752-0150
Q214	Type 2N1131	8210-1025	96214	2N1131	5960-788-8644
Q501	Type 2N1304	8210-1304	01295	2N1304	5961-892-0800
Q503	Type 2N3702	8210-1106	01295	2N3702	

## PARTS LIST (Cont)

Ref. Desig.	Description	GR Part No.	FMC	Mfg. Part No.	Fed. Stock No.
<b>TRANSISTORS (Cont)</b>					
Q504	Type 2N1304	8210-1304	01295	2N1304	
Q505	Type 2N1304	8210-1304	01295	2N1304	5961-892-0800
Q506	Type 2N3416	8210-1047	24446	2N3414	5961-892-0800
Q901	Type 2N1540	8210-1540	80211	2N1540	5961-989-2749
<b>DIODES</b>					
CR201	Semiconductor, Type 1N455	6082-1010	07910	1N455	5960-877-8255
CR202	Semiconductor, Type 1N455	6082-1010	07910	1N455	5960-877-8255
CR203	Semiconductor, Type 1N455	6082-1010	07910	1N455	5960-877-8255
CR204	Semiconductor, Type 1N455	6082-1010	07910	1N455	5960-877-8255
CR501	Semiconductor, Type 1N3253	6081-1001	79089	1N3253	5961-814-4251
CR502	Semiconductor, Type 1N3253	6081-1001	79089	1N3253	5961-814-4251
CR503	Semiconductor, Type 1N3253	6081-1001	79089	1N3253	5961-814-4251
CR504	Semiconductor, Type 1N3253	6081-1001	79089	1N3253	5961-814-4251
CR505	Semiconductor, Type 1N645	6082-1016	24446	1N645	5961-814-4251
CR506	Zener, Type 1N759A	6083-1014	81349	1N759A	5961-944-8222
CR507	Semiconductor, Type 1N816	6083-1001	98925	1N816	5961-846-9157
CR508	Semiconductor, Type 1N935	6083-1026	07910	1N935	
CR509	Semiconductor, Type 1N3253	6081-1001	79089	1N3253	5960-760-9599 5961-814-4251
<b>INDUCTORS</b>					
L101	Choke, 12 $\mu$ H 10%	4300-2300	99800	1537-38, 12 $\mu$ H $\pm$ 10%	
L201	Adjustable, 2.18 $\mu$ H .07%	1234-2050	24655	1234-2050	5950-807-6050
L901	Choke, 5.6 $\mu$ H 10%	4300-1800	(Part of 0874-4310)		
L902	Choke, 9.5mH 2.5mH	1234-2080	24655	1234-2080	
<b>FUSE</b>					
F901	Slo-Blo, 0.2 amp 3AG	5330-0600	71400	MDL, 0.2 Amp.	
<b>METER:</b>					
M101	Mirrored Scale	5730-1402	40931	143010-0101	
<b>SWITCHES</b>					
S901	(Part of R912)	Included in 6045-2020			
S902	Slide DPST	7910-0831	42190	4603	
S903	Rotary Wafer	7890-4770	76854	265267-F1	
S904	Rotary Wafer	7890-4760	76854	265055-H3	
S905	Rotary Wafer	7890-4750	76854	265054-F1	
S906	Rotary Wafer	7890-4780	76854	265057-F4	
S907	Toggle, SPST	7910-0790	95146	MST-105D	
<b>TRANSFORMERS</b>					
T901	Power	0745-4460	24655	0745-4460	
T902	Coupling	1234-2070	24655	1234-2070	
<b>PLUGS</b>					
PL901	Power, 3 wire	4200-1903	24655	4200-1903	
PL902	Jones, 4 pin	4220-4400	71785	P-304-AB	



## PARTS LIST (Cont)

Ref. Desig.	Description	GR Part No.	FMC	Mfg. Part No.	Fed. Stock No.
<b>JACKS</b>					
J903	Phone, NS	4260-1031	82389	N111	
J902	Phone, NS	4260-1031	82389	N111	
J901	GR874 Coaxial	0874-4310	24655	0874-4310	

### PILOT LIGHT

P901	Bayonet Base, 28 V	5600-0307	71744	#327	
P902	Bayonet Base, 28 V	5600-0307	71744	#327	
P903	Bayonet Base, 28 V	5600-0307	71744	#327	
P904	Bayonet Base, 28 V	5600-0307	71744	#327	
P905	Bayonet Base, 28 V	5600-0307	71744	#327	

### MISCELLANEOUS ASSEMBLIES AND MECH. PARTS

Memory Dial Asm	1234-2040	24655		
Preamplifier Etched Cir. Board	1234-2711			
Output Amp. Etched Cir. Board	1234-2721			
Power Supply Etched Cir. Board	1234-2753			
Attenuator Dial	1234-8091			
Meter-Scale Knob	5500-1702			
Source Knob	5500-1800			
ΔdB Knob	5530-0400			
Attenuator Knob (Coarse)	5540-2903			
Freq. KHz Knob	5540-3000			
Attenuator Knob (Fine)	5540-3323			
Gasket, Panel	5331-2104			
Meter Cover, Clear Plastic	ME-6-701 (Honeywell)			

PART NUMBERS FOR THE ITEMS INCLUDED IN THE TYPE 1538-P3 BATTERY AND CHARGER	
1538-0150	Battery Power Case
1538-0240	Leather Carrying Case
1538-0250	Battery Charger
1538-0260	Nickel-Cadmium Battery

## APPENDIX

### BATTERY OPERATION.

The stroboscope will also operate on 24V dc. The Type 1538-P3 Battery and Charger (Figure A-1) is recommended for this type of operation. The dc power also is applied at the 4-prong plug on the side panel.

The fuse in the 1234 is not in the circuit for dc operation, but protection is maintained by the 1-A fuse mounted on the battery case.

### TYPE 1538-P3 BATTERY AND CHARGER.

The Type 1538-P3 Battery and Charger (Figure A-1) is available as an optional accessory. It includes a rechargeable nickel-cadmium battery and an automatic battery charger, mounted together in a leather carrying case with an adjustable shoulder strap.

The battery power cable is permanently attached to the battery. For battery operation mate the socket on the end of the cable with the 4-prong plug (labelled BATT) side on the panel. The cable is locked to the panel by the two clips on the socket; to remove the cable, press the clips toward each other with thumb and forefinger.

When not in use, the ac power cable should be carried in the leather carrying case.



Figure. A-1. Battery and Charger.

**PART NUMBERS FOR THE ITEMS INCLUDED IN THE TYPE 1538-P3 BATTERY AND CHARGER.**

Item	Part Number
Nickel-Cadmium Battery	1538-4310
Battery Charger	1538-4300
Leather Carrying Case	1538-8340
Battery Power Cable	1538-0480

**THE BATTERY**

The battery consists of 20 sealed cylindrical G.E. cells, which supply 24V at 2 A-hr. The cells incorporate a resealing, safety vent mechanism (Figure A-2) that will not open during normal battery usage; but, should excessive gas pressure build up within the cell, the vent opens at a predetermined internal pressure. This pressure build-up causes distortion of the "O" ring and creates a gas path to the atmosphere. When pressure within the cell returns at atmospheric pressure, the "O" ring returns to its original shape and position, and reseals the opening.

**THE CHARGER**

The charger included in the Type 1538-P3 Battery and Charger is a constant-current type and plugs directly into the battery. A two-prong plug on the button of the charger case mates with a socket on the top of the battery. One end of the power-line cable (P/N 4200-1924), is permanently attached to the charger. A switch on the side of the charger case must be set for either 115 V, 60 Hz or 230 V, 50 Hz, depending upon the source of power to be used for charging. Be sure the power-line cable is connected to a power source that corresponds with the position of the switch.

To charge the battery:

- a. Plug the charger into the battery and connect the charger power-line cable to the source of power.
- b. Turn the automatic-timer dial on the charger to the desired number of hours of charging.

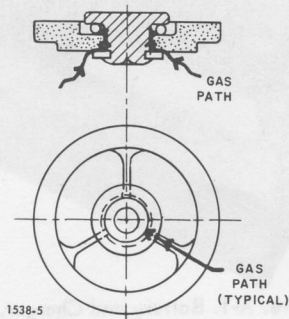

Figure A-2. The resealable vent in the General Electric battery cells.

**NOTE**

If the charger is used on a 50-Hz line, the charging time will be somewhat longer than is indicated by the numbers on the dial.

At the end of this time, the charger will switch automatically to trickle charge, which will continue until the dial is reset or the line power is removed from the charger.

When first received, the battery should be charged for about 10 hours. With the automatic timer, a completely discharged battery can be charged to 70% of full capacity in 10 hours. A fully charged battery will power the Type 1234 for about 8 hours of normal, intermittent operation, after which a 10-hour, overnight charge should be adequate to return the battery to 100% capacity. If the maximum operating time has been approached, a full 14-16 hours will be required to recharge the battery to full capacity (as shown by the curves). With no warm-up time required by the Type 1234, the POWER switch should always be turned OFF when the instrument is not in use, to conserve the charge.

Although the life of the battery cells may be somewhat shortened by continual overcharging in the constant-current mode, they can be left on trickle charge for an indefinite period.

The cell life of the battery is reduced by:

- Repeated complete or nearly complete discharging of the battery;
- Severe overcharging.

Under average operating conditions, the number of charge/discharge cycles may exceed 5000 before replacement of the battery becomes necessary. However, if the battery is deeply discharged, a cycle life as low as 300 may result. If the state of charge of the battery is unknown, recharge it for ten hours.

Continuous trickle charging will maintain 100% capacity of the battery during prolonged storage periods. The battery will discharge with time if trickle charging is not used; the rate of discharge depends on the storage temperature, as shown in Figure A-3.

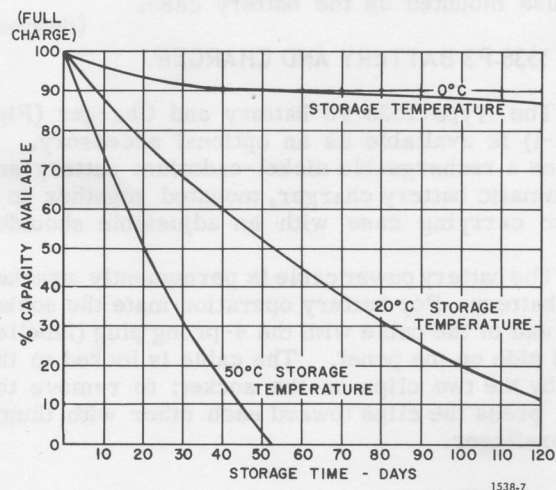

Figure A-3. Typical charge retention characteristics of the battery.

# GENERAL RADIO COMPANY

WEST CONCORD, MASSACHUSETTS 01781

617 369-4400

617 646-7400

## DISTRICT OFFICES

### **METROPOLITAN NEW YORK\***

845 Broad Avenue  
Ridgefield, New Jersey 07657  
Telephone N.Y. 212 964-2722  
N.J. 201 943-3140

### **SYRACUSE**

Pickard Building  
East Molloy Road  
Syracuse, New York 13211  
Telephone 315 454-9323

### **NEW ENGLAND\***

22 Baker Avenue  
West Concord, Massachusetts 01781  
Telephone 617 646-0550

### **PHILADELPHIA**

Fort Washington Industrial Park  
Fort Washington, Pennsylvania 19034  
Telephone 215 646-8030

### **WASHINGTON\* AND BALTIMORE**

11420 Rockville Pike  
Rockville, Maryland 20852  
Telephone 301 946-1600

### **ORLANDO**

113 East Colonial Drive  
Orlando, Florida 32801  
Telephone 305 425-4671

\* Repair services are available  
at these district offices.

### **CHICAGO\***

9440 W. Foster Avenue  
Chicago, Illinois 60656  
312 992-0800

### **CLEVELAND**

5579 Pearl Road  
Cleveland, Ohio 44129  
Telephone 216 886-0150

### **LOS ANGELES\***

1000 North Seward Street  
Los Angeles, California 90038  
Telephone 213 469-6201

### **SAN FRANCISCO**

626 San Antonio Road  
Mountain View, California 94040  
Telephone 415 948-8233

### **DALLAS\***

2600 Stemmons Freeway, Suite 210  
Dallas, Texas 75207  
Telephone 214 637-2240

### **TORONTO\***

99 Floral Parkway  
Toronto 15, Ontario, Canada  
Telephone 416 247-2171

### **MONTREAL**

1255 Laird Boulevard  
Town of Mount Royal, Quebec, Canada  
Telephone 514 737-3673

OTTAWA Telephone 613 233-4237

General Radio Company (Overseas), 8008 Zurich, Switzerland  
General Radio Company (U.K.) Limited, Bourne End, Buckinghamshire, England  
Representatives in Principal Overseas Countries

Printed in USA